

Neutrino Program in India

NEUTRINO

Sanjib Kumar Agarwalla

sanjib@iopb.res.in

Institute of Physics, Bhubaneswar, Orissa, India



Dealing with Neutrinos: An Exercise in Patience

Three most fundamental questions were being asked in the past century...

1. How tiny is the neutrino mass? (Pauli, Fermi, '30s)

Recent Planck satellite data set an upper limit of **0.23 eV** for the sum of neutrino masses!

Planck Collaboration, arXiv:1303.5076 [astro-ph.CO]

2. Can a neutrino turn into its own antiparticle? (Majorana, '30s)

Hunt for ν -less Double- β decay ($Z, A \rightarrow Z+2, A$) is still on, demands **lepton number violation!**

Nice Review by Avignone, Elliott, Engel, Rev.Mod.Phys. 80 (2008) 481-516

3. Do different ν flavors 'oscillate' into one another? (Pontecorvo, Maki-Nakagawa-Sakata, '60s)

B. Pontecorvo, Sov. Phys. JETP 26, 984 (1968) [Zh. Eksp. Teor. Fiz. 53, 1717 (1967)]

Last question positively answered only in recent years. Now an established fact that **neutrinos are massive** and leptonic flavors are not **symmetries of Nature!**

Recent measurement of θ_{13} , a clear first order picture of the 3-flavor lepton mixing matrix has emerged, signifies a major breakthrough in ν physics!

This year marks the 100th anniversary of the birth of Pontecorvo, a great tribute to him!

Neutrino Program in India

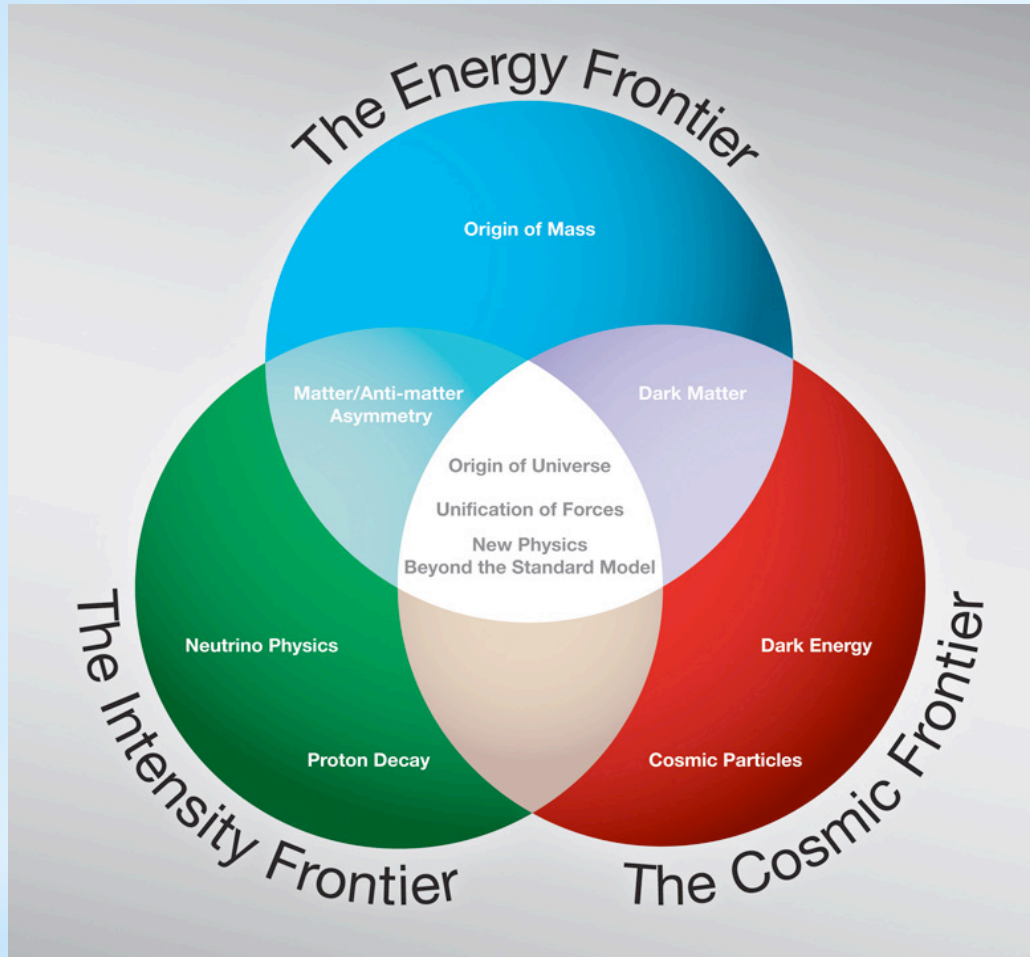

Two major funding agencies:

Department of Atomic Energy (DAE)

Department of Science & Technology (DST)

The Intensity Frontier:

India-based Neutrino Observatory

- **Iron Calorimeter Detector (ICAL)**
- **$0\nu\beta\beta$ decay searches (Tin.Tin)**
- **Direct DM searches (DINO)**

Collaboration at FNAL

- **MIPP, MINOS+, NOvA, LBNE**

Strong support from
the community and
the funding agencies

Kolar Gold Field Underground Laboratory in India

Atmospheric neutrino detection in 1965

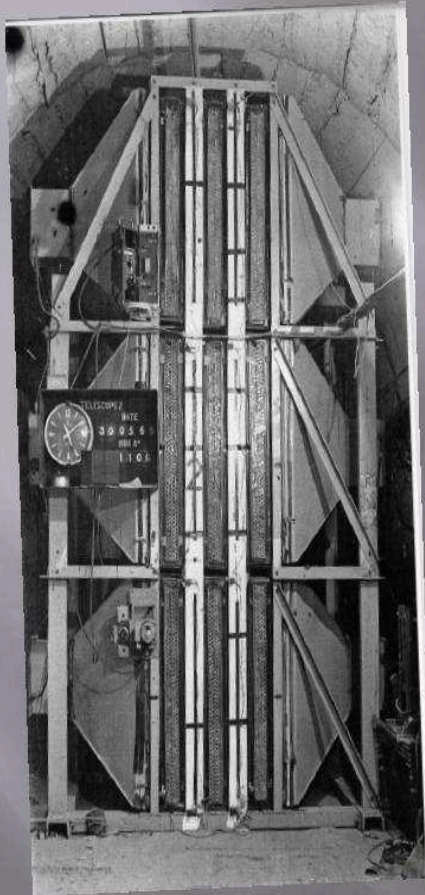

Atmospheric neutrino detector
at Kolar Gold Field -1965

DETECTION OF MUONS PRODUCED BY COSMIC RAY NEUTRINO
DEEP UNDERGROUND

C. V. ACHAR, M. G. K. MENON, V. S. NARASIMHAM, P. V. RAMANA MURTHY
and B. V. SREEKANTAN,

Tata Institute of Fundamental Research, Colaba, Bombay

K. HINOTANI and S. MIYAKE,
Osaka City University, Osaka, Japan

D. R. CREED, J. L. OSBORNE, J. B. M. PATTISON and A. W. WOLFENDALE
University of Durham, Durham, U.K.

Received 12 July 1965

Physics Letters 18, (1965) 196, dated 15th Aug 1965

EVIDENCE FOR HIGH-ENERGY COSMIC-RAY NEUTRINO INTERACTIONS*

F. Reines, M. F. Crouch, T. L. Jenkins, W. R. Kropp, H. S. Gurr, and G. R. Smith

Case Institute of Technology, Cleveland, Ohio

and

J. P. F. Sellschop and B. Meyer

University of the Witwatersrand, Johannesburg, Republic of South Africa

(Received 26 July 1965)

PRL 15, (1965), 429, dated 30th Aug. 1965

- *KGF: Deepest underground lab in world till 1992 > 6500 MWE*
- *In 1965, at KGF at a depth of 2.3km, first atmospheric neutrino was observed by the TIFR-Osaka-Durham group*
- *During early 80s dedicated detectors were setup at KGF by TIFR-Osaka collaboration to look for proton decay*

INO Collaboration



Ahmadabad: Physical Research Laboratory
Aligarh: Aligarh Muslim University
Allahabad: HRI
Bhubaneswar: IoP, Utkal University
Calicut: University of Calicut
Chandigarh: Panjab University
Chennai: IIT-Madras, IMSc
Delhi: University of Delhi
Kalpakkam: IGCAR
Kolkata: SINP, VECC, University of Calcutta
Lucknow: Lucknow University
Madurai: American College
Mumbai: BARC, IIT-Bombay, TIFR, CMEMS
Mysore: University of Mysore
Srinagar: University of Kashmir
Varanasi: Banaras Hindu University

Nearly 100 scientists from 23 research institutes & universities all over India

One of the largest basic science projects in India in terms of man power & cost as well !

We are growing day by day!

Collaborators are most welcome!

India-Based Neutrino Observatory

- *A multi-institutional attempt to build a world-class underground facility to study fundamental issues in science with special emphasis on neutrinos*
- *With ~1 km all-round rock cover accessed through a 2 km long tunnel.
A large and several smaller caverns to pursue many experimental programs*
- *Complementary to ongoing efforts worldwide to explore neutrino properties*
- *A mega-science project (~250 M\$) in India, jointly funded (50:50) by the Department of Atomic Energy and the Department of Science and Technology*
- *INO project was discussed and approved by the Atomic Energy Commission on 17th August, 2013 at New Delhi*
- *Regarding Final approval: Clearance from the Cabinet expected soon*
- *International Community is welcome to participate in ICAL@INO as well as the INO facility is available to the entire community for setting up experiments like Neutrino-less Double Beta Decay, Direct Dark Matter searches*

Location of INO & Unique Features

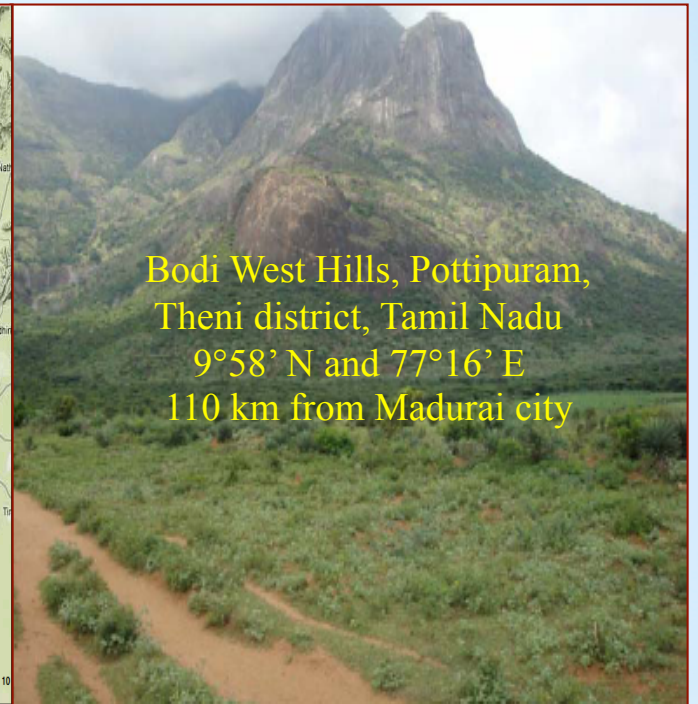
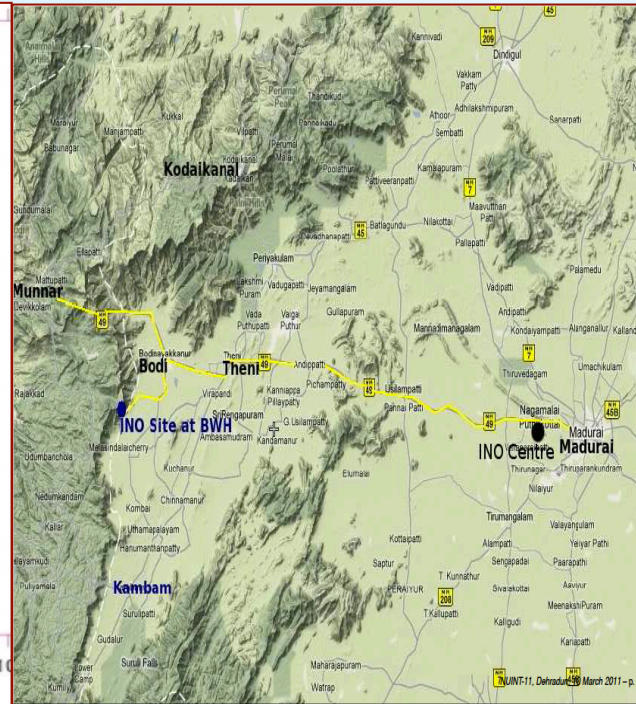
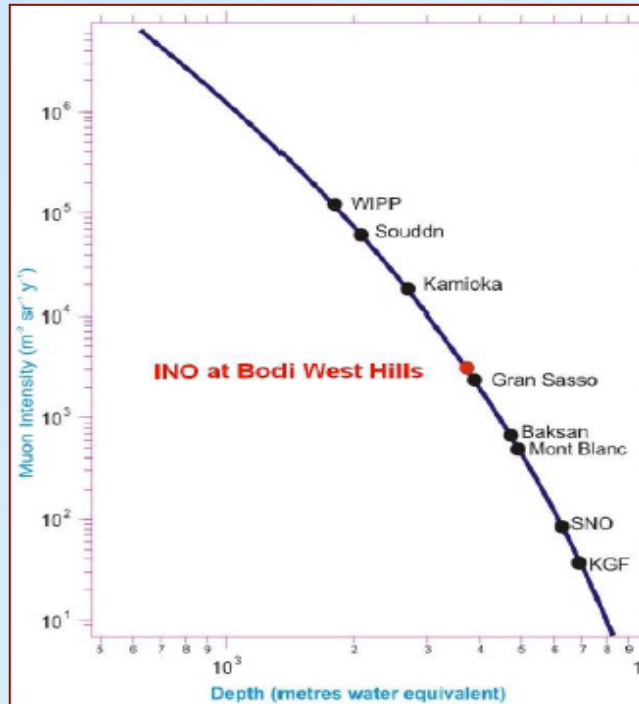

Bodi West Hills, Pottipuram,
Theni district, Tamil Nadu
9°58' N and 77°16' E
110 km from Madurai city

- **Transport:** *Flat terrain with good access from major roads*
- **Geotechnical Issues:** *Good rock quality, Cavern set in massive Charnockite rock under the 1589 m peak, Vertical cover approx. 1289 m, Tunnel length 1.91 km*
- **Weather :** *Warm, low rainfall area, low humidity throughout the year*

Approved projects under INO

- Come up with an underground lab & surface facilities near Pottipuram village in Theni district of Tamil Nadu
- Build massive 50 kt magnetized Iron calorimeter (ICAL) detector to study properties of neutrinos
- Construction of INO centre at Madurai: Inter-Institutional Centre for High Energy Physics (IICHEP)
- Human Resource Development (INO Graduate Training Program)
- Completely in-house Detector R&D with substantial INO-Industry interface
- **Time Frame for 1st module: 2018**

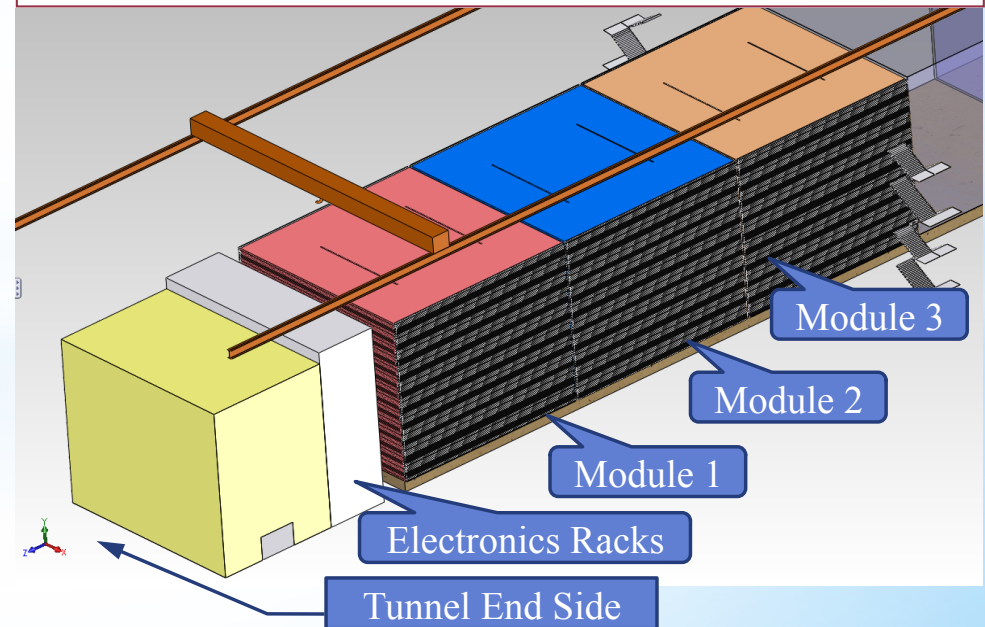
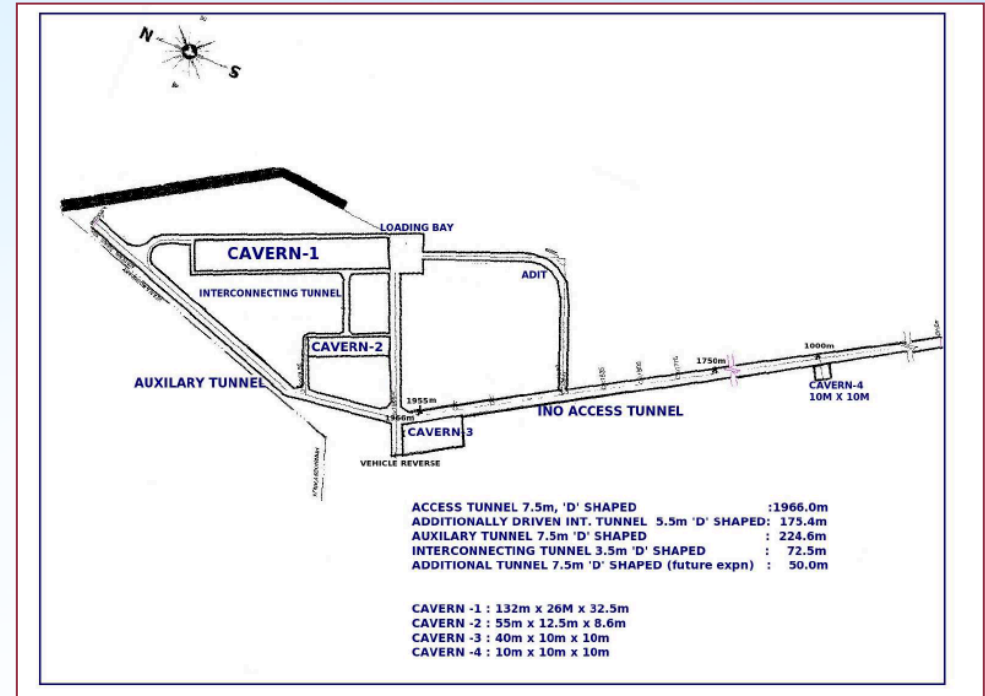

Human Resource Development and Training



- **INO Graduate Training Program started in August 2008, students are affiliated to HBNI**
- **At present students being trained for 1 year at TIFR in both experimental techniques & theory**
- **After completion of coursework, attached to Ph.D. guides at various collaborating institutions**
- **Many short/long term visits to RPC labs (Mumbai & Kolkata) of students & faculties from Universities in last several years**
- **Several students from 1st batch (2008) are at the final stage of writing their theses. Few of them have already received good post-doctoral offers from various experiments**
- **6th batch of 7 students have started their course work at TIFR this year**

Recent Updates on the Site Front

- ★ *INO project approved by DST & DAE*
- ★ *All Environmental and Forest clearances obtained*
- ★ *26.82 hectares of revenue land at Pottipuram village transferred to DAE*
- ★ *Survey work for site preparation under progress & fencing work started*
- ★ *Funds transferred to the Tamil Nadu government for construction of approach roads & water connection to the INO site. Work already started*
- ★ *At Madurai, 12.5 hectares of land transferred to establish the IICHEP. Survey work over & construction of boundary wall started*
- ★ *Work order placed for geotechnical studies, pre-qualification bids invited for the construction of detector lab*
- ★ *IICHEP at Madurai already started its operation from a rental building*
- ★ *INO project engineers & scientific officers already stationed at this place and establishment work for RPC detector lab initiated*

Physics Issues with ICAL-INO in Phase 1

Study Atmospheric neutrinos w/ a wide range of Baselines & Energies

Recent discovery of large θ_{13} : A great news for ICAL-INO

What do we want to achieve?

- ❖ *Reconfirm neutrino oscillations using neutrinos and anti-neutrinos separately*
- ❖ *Improved precision of atmospheric oscillation parameters*
- ❖ *Determine neutrino mass hierarchy using matter effects via charge discrimination*
- ❖ *Measure the deviation of 2-3 mixing angle from its maximal value and its octant*
- ❖ *Test bed for various new physics like NSI, CPT violation, long range forces*
- ❖ *Detect Ultra High Energy Neutrinos, Cosmic Muons, Indirect searches of DM*

What kind of Detector do we need?

- *Should have large target mass (50 – 100 kt)*
- *Good tracking and Energy resolution (tracking calorimeter)*
- *Good directionality for up/down discrimination (nano-second time resolution)*
- *Charge identification (need to have uniform, homogeneous magnetic field)*
- *Ease of construction & Modularity*
- *Complementary to the other existing and proposed detectors*

What is the ideal choice?

Magnetized iron (target mass): ICAL

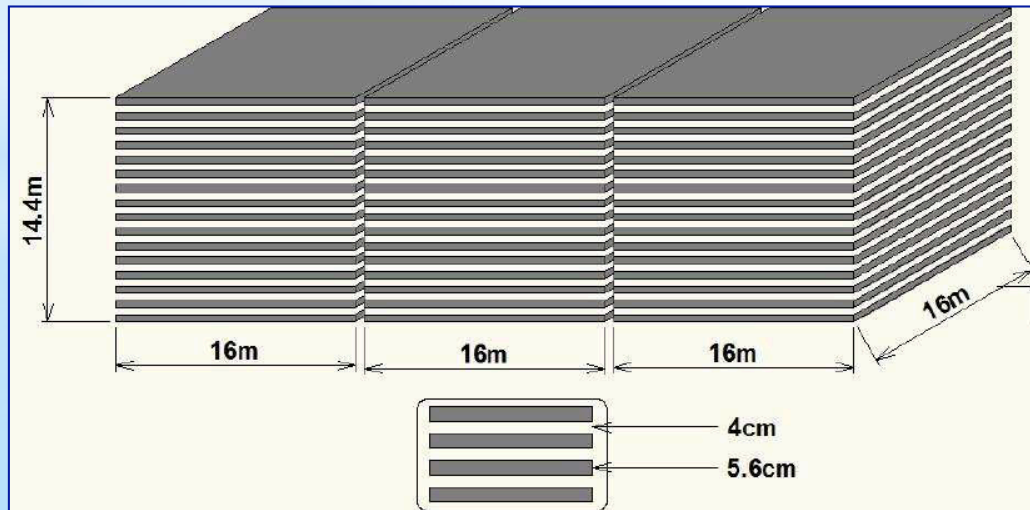

RPC (active detector element)

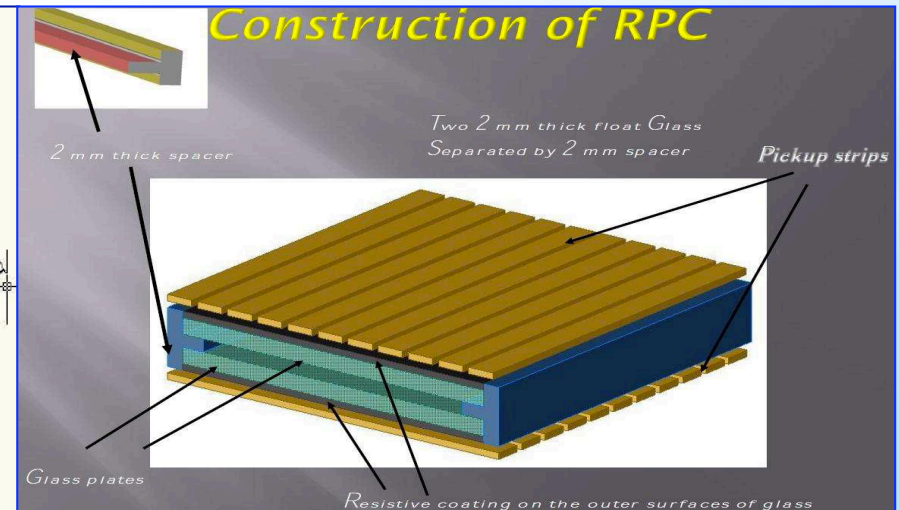

Specifications of the ICAL Detector

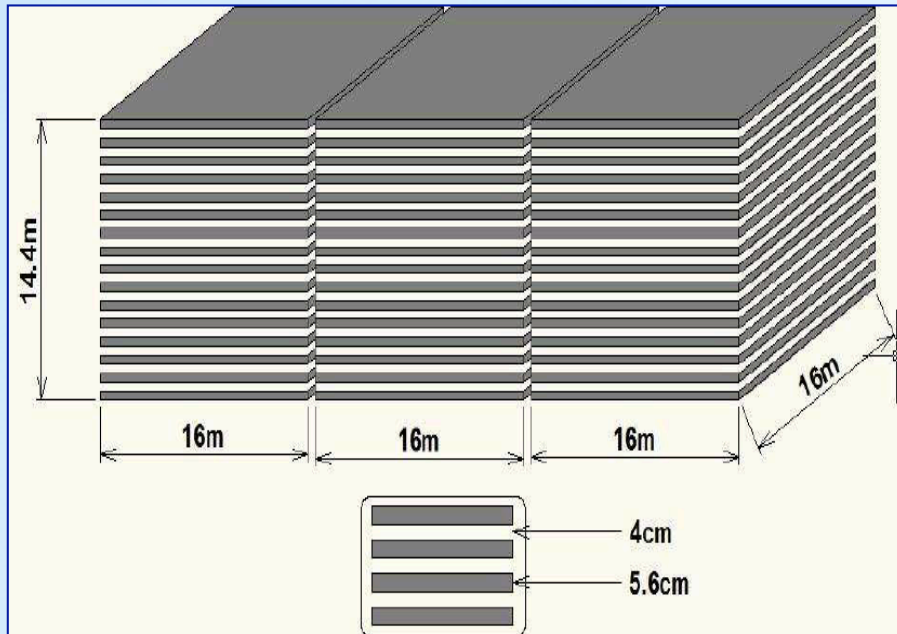

No. of modules	3
Module dimensions	16m × 16m × 14.5m
Detector dimensions	48.4m × 16m × 14.5m
No. of layers	150
Iron plate thickness	56mm
Gap for RPC trays	40mm
Magnetic field	1.3 Tesla
RPC dimensions	1,950mm × 1,840mm × 24mm
Readout strip pitch	30mm
No. of RPCs/Road/Layer	8
No. of Roads/Layer/Module	8
No. of RPC units/Layer	192
No. of RPC units	28,800 (97,505m ²)
No. of readout strips	3,686,400

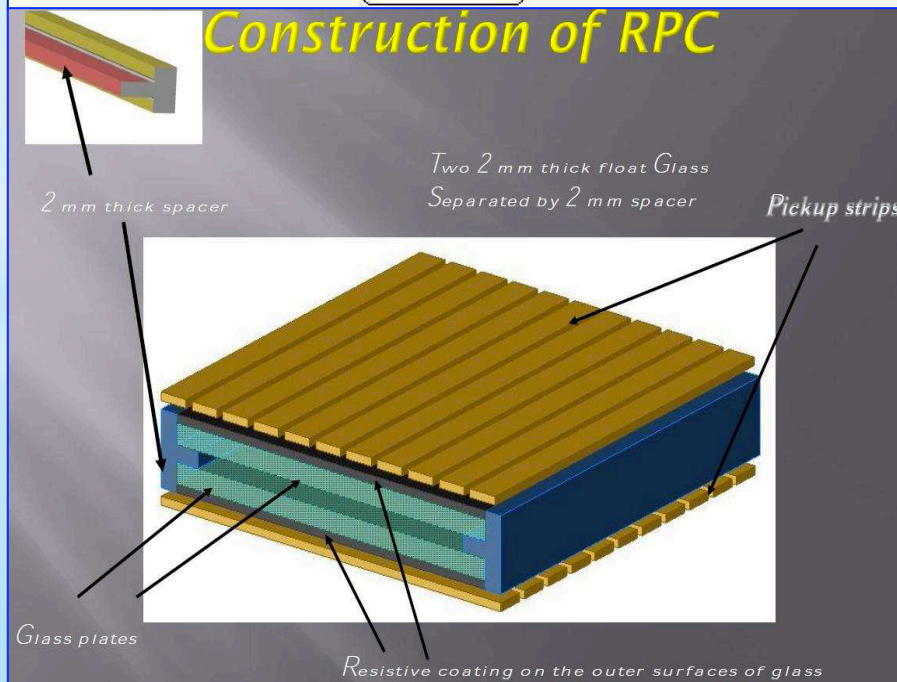

Rapid progress in all fronts
2011-2013: A productive phase for INO
Several milestones achieved

Current Status of RPC Detector Development

- *R&D almost over. Full size RPCs (2m X 2m) are now being fabricated not only in our lab but also by the Industry*
- *Identified several Industrial Partners: Keen in mass production of RPCs*
- *They are producing components needed for RPC making, also designing tools for mass production of RPCs. Spacers for new RPC design received*
- *Development of graphite coating by automatic spray painting*
- *Demonstration of successful operation of automatic button & glue dispenser*
- *Development of glass chamfering & engraving, pickup panel, tray design*
- *Computer modeling of RPC & its assembly in ICAL*
- *Physical RPC model to study push-pull assembly in ICAL magnet gap*
- *Floating tender for the production of 400 RPCs for the Engineering module of 8m × 8m × 20 layers (800 ton) to be assembled at Madurai*
- *Prototype for close loop gas circulation system is under test at TIFR*

Fabricating Glass RPCs at TIFR

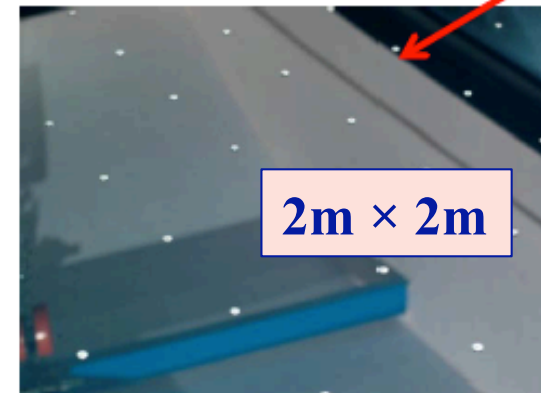
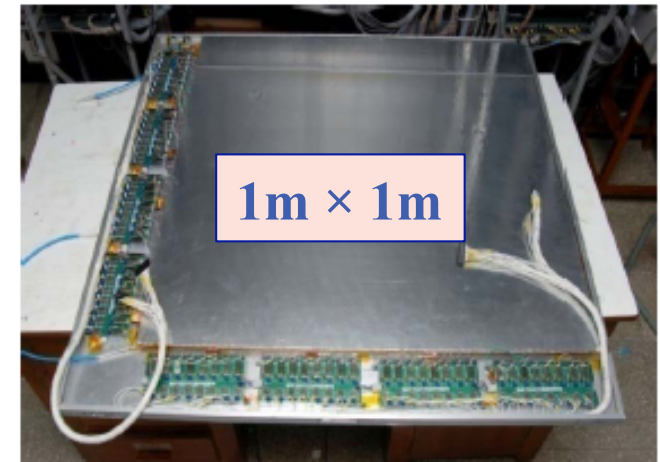
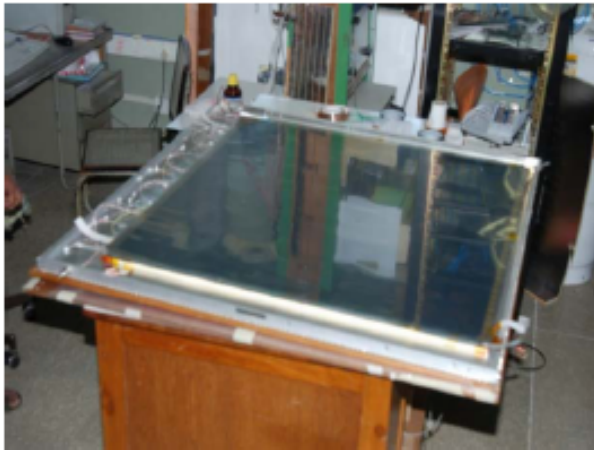

- *30 glass RPCs of 1m x 1m developed, tested for long in avalanche mode*
- *5 glass RPCs of 2m x 2m successfully assembled and tested*

Bakelite RPC R&D at VECC & SINP (Kolkata)

- *Bakelite RPCs being developed, operating in streamer mode, inner surface coated with PDMS (silicone) for smooth surface, efficiency plateau over 96% with reduced noise rate and long term stability*
- *ICAL@INO being modular in size, can use both glass as well as bakelite RPCs*

13 layers of soft iron

Each Iron Plate: 2.48m x 2.17m x 0.05m

12 layers of 1m × 1m RPCs

8 glass RPCs and 4 Bakelite RPCs

Total of 4 coils, each having 5 turns

perpendicular to the plane of the Fe (1.6 Tesla)

512 channels of preamp for 8 glass RPCs

timing discriminators for avalanche RPCs

Designed to study the working behavior of RPCs together with the front end electronics in presence of magnetic field

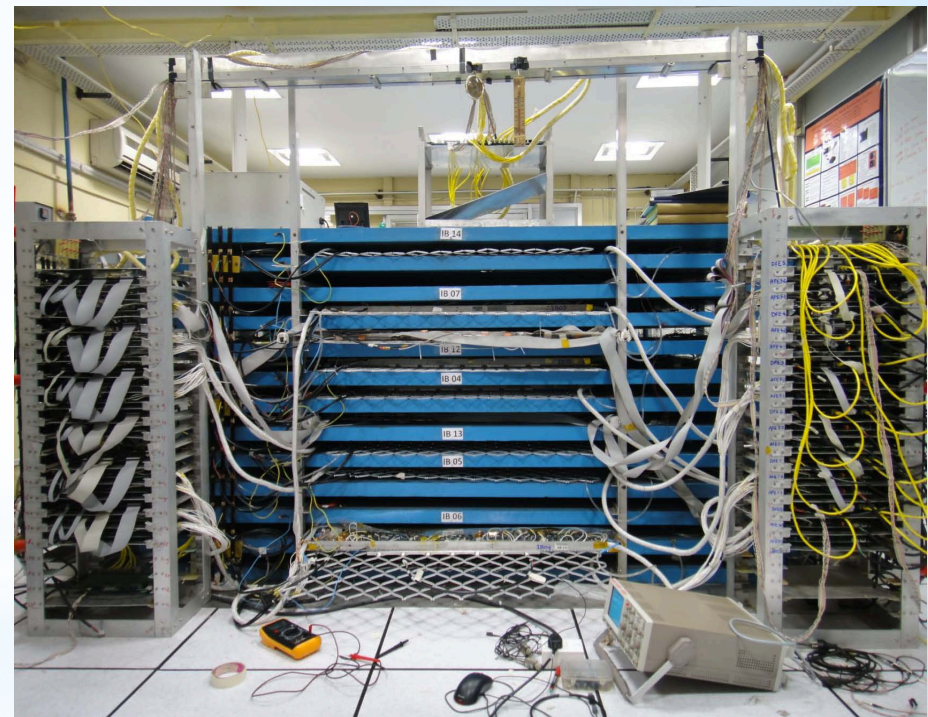

*ICAL@INO Prototype Detector ~ 50 tons
Total Height 1.302 m*

Various Components of ICAL Electronics

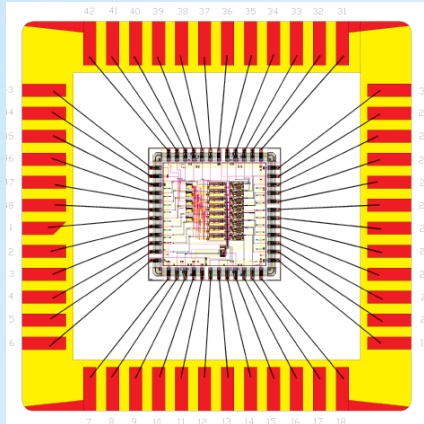

Front-end ASIC

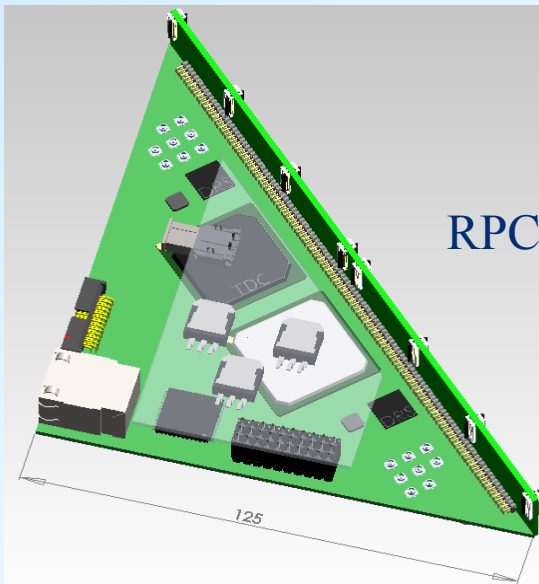

RPCDAQ

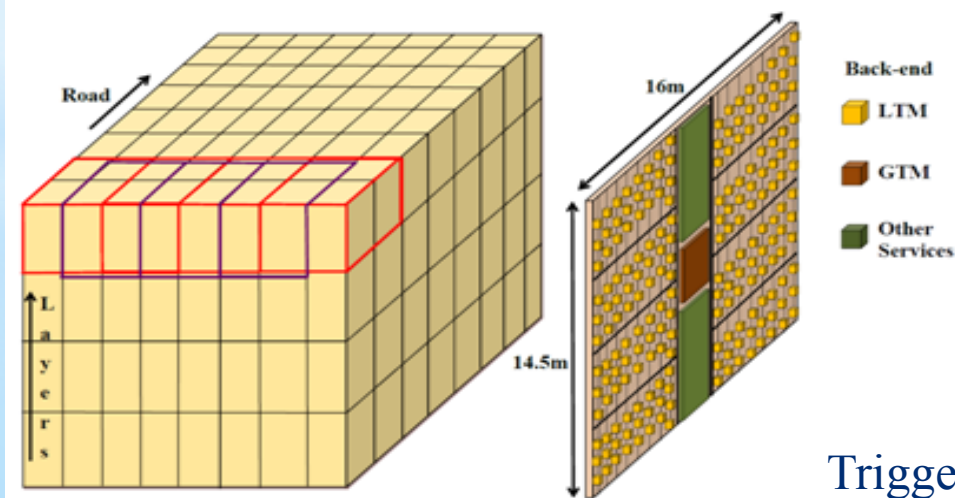
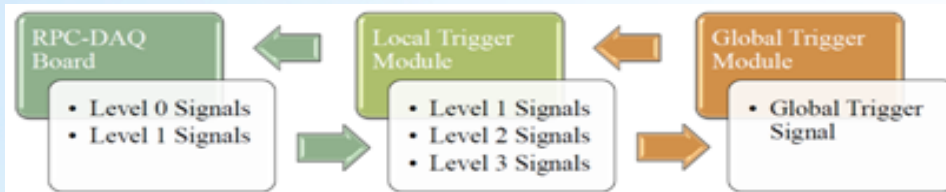
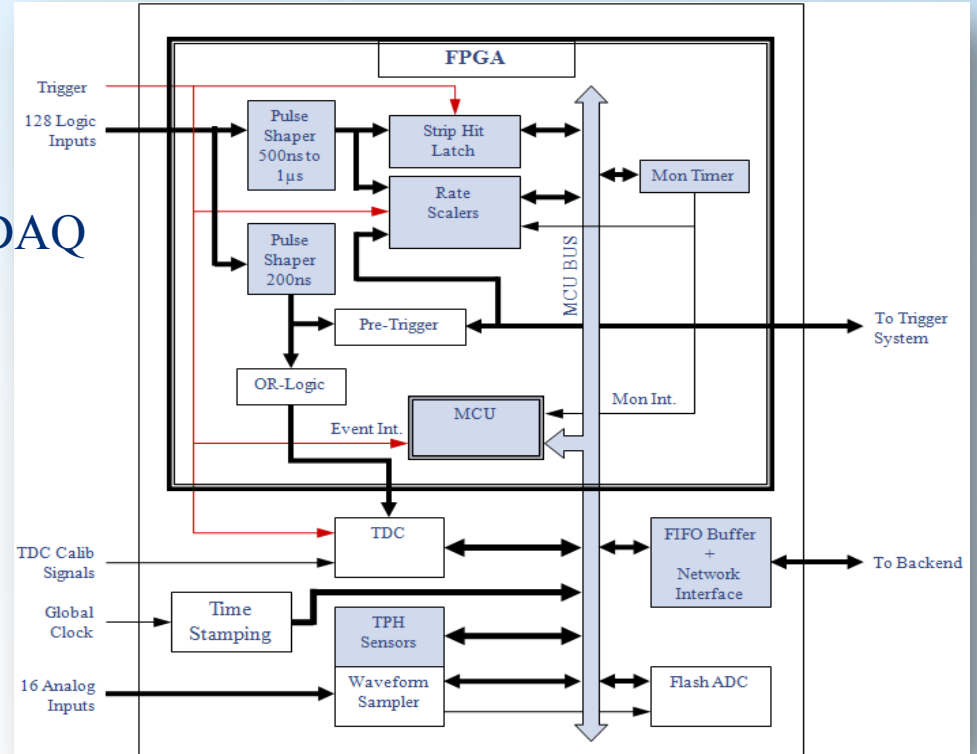

Trigger

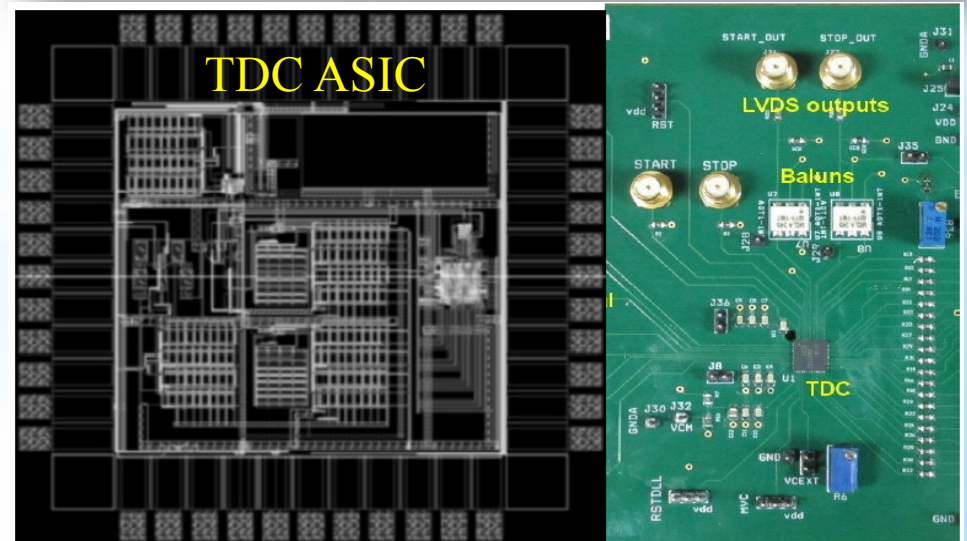

Muon Efficiencies and Resolutions

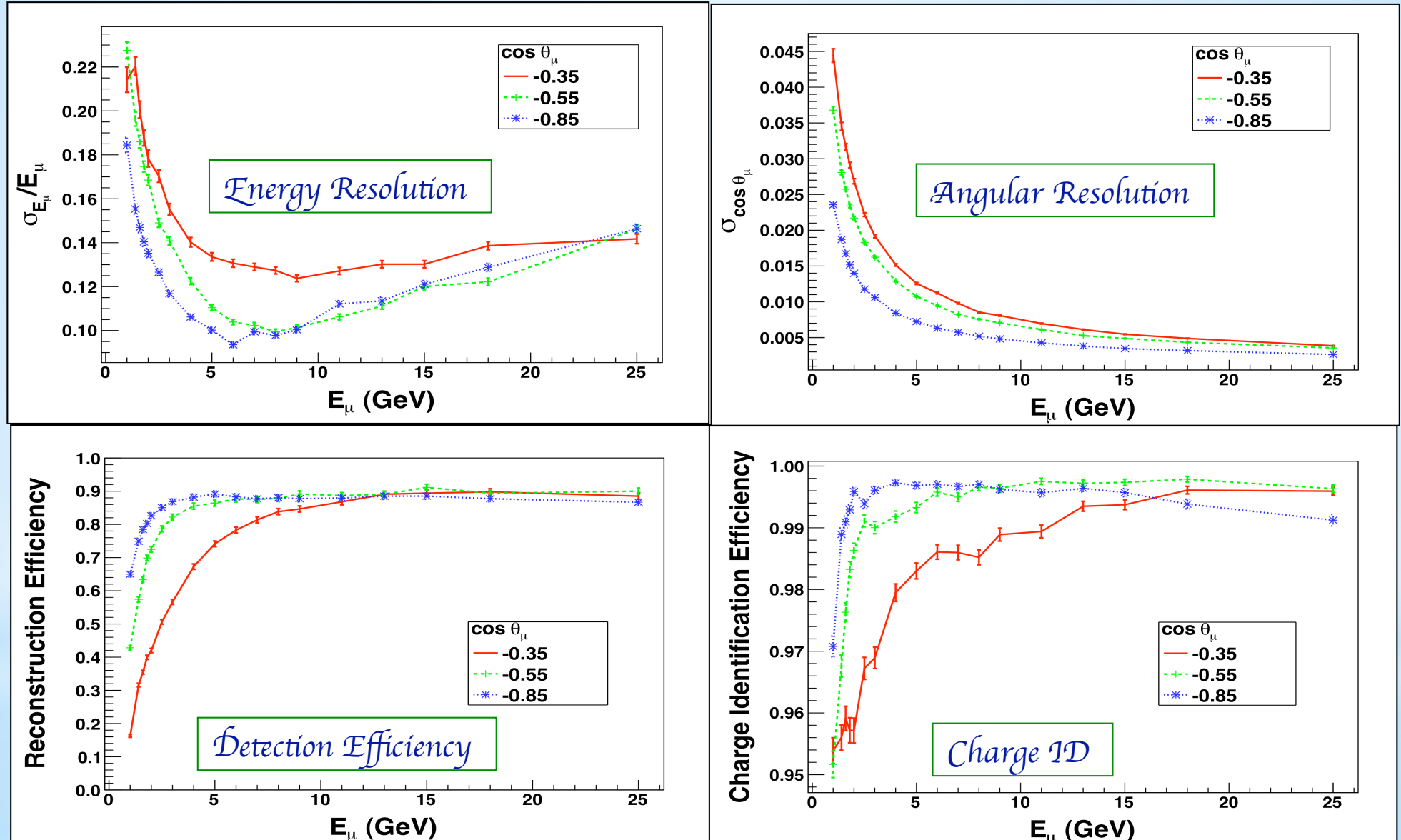

Animesh, Meghna, Kanishka, Tarak et al., in preparation

Mass Ordering with ICAL-INO

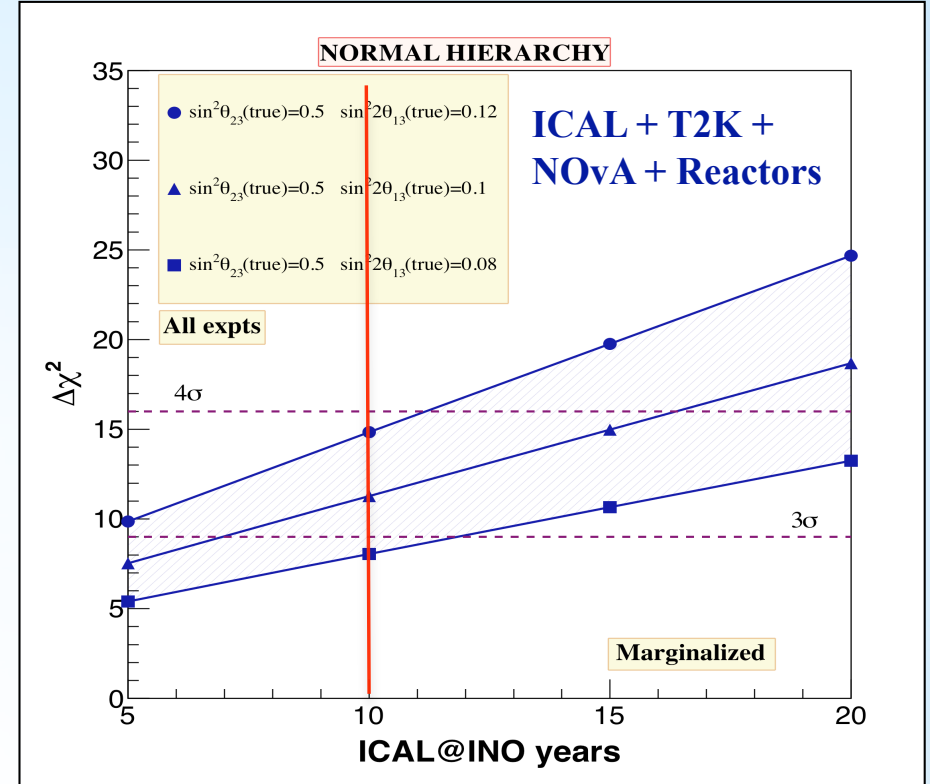
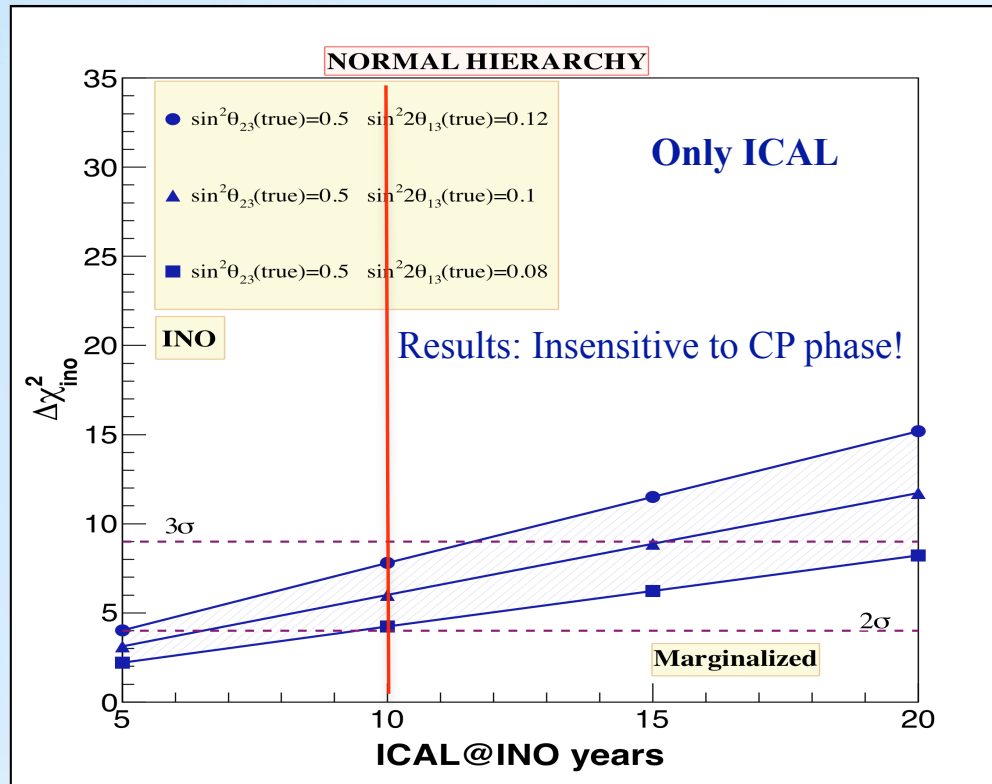

All systematic uncertainties are included!

Ghosh, Thakore, Choubey, JHEP 1304 (2013) 009

Events generated with NUANCE! Two Dimensional Muon analysis with ICAL resolutions!
 $E_\mu = 20$ energy bins in the range 1 GeV to 11 GeV, $\text{Cos}\theta_\mu = 80$ angular bins in the range -1 to +1

For $\sin^22\theta_{13} = 0.1$ & $\sin^2\theta_{23} = 0.5$, Only ICAL with 500 kt-years exposure: **2.5σ MH discovery**

ICAL + T2K + NOvA + Double Chooz + RENO + Daya Bay: **3.4σ MH discovery**

Interesting synergy between atmospheric, accelerator, and reactor data!

Precision of Atmospheric Oscillation Parameters

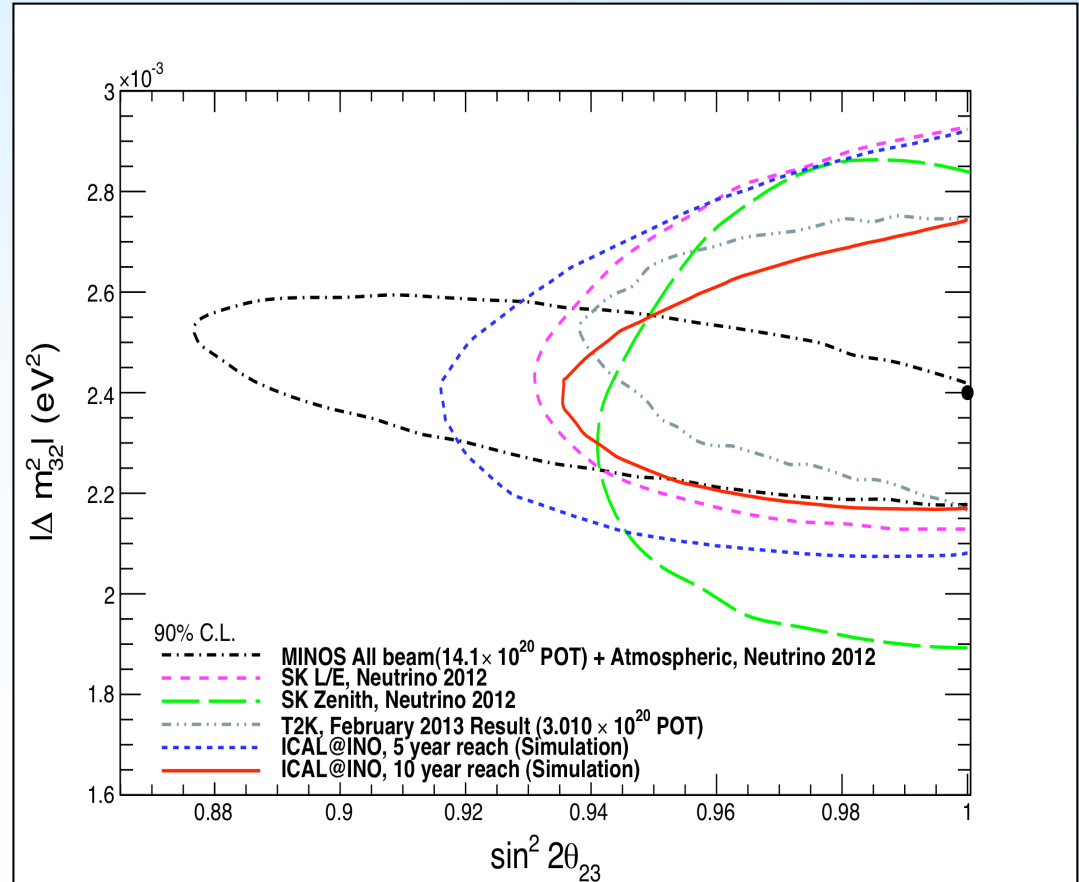
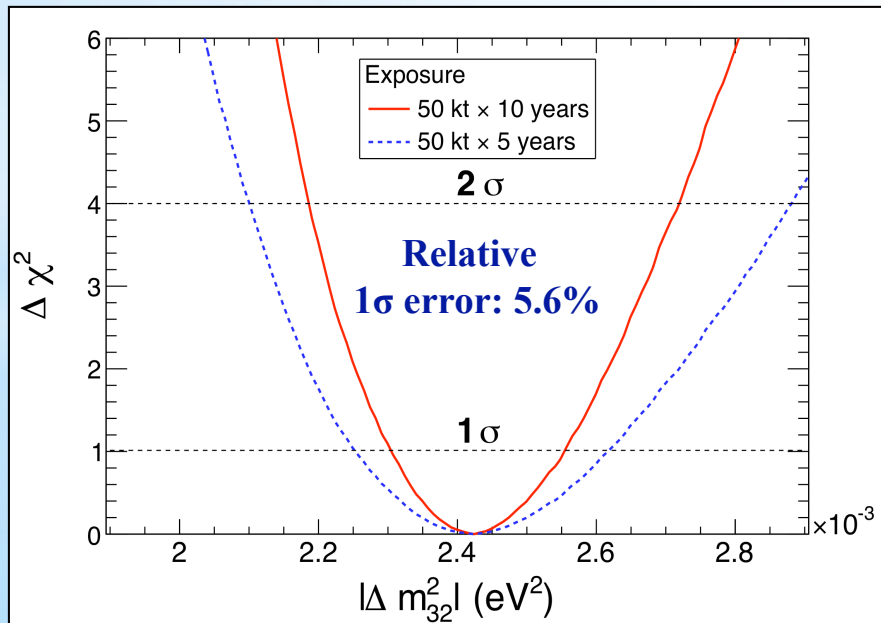
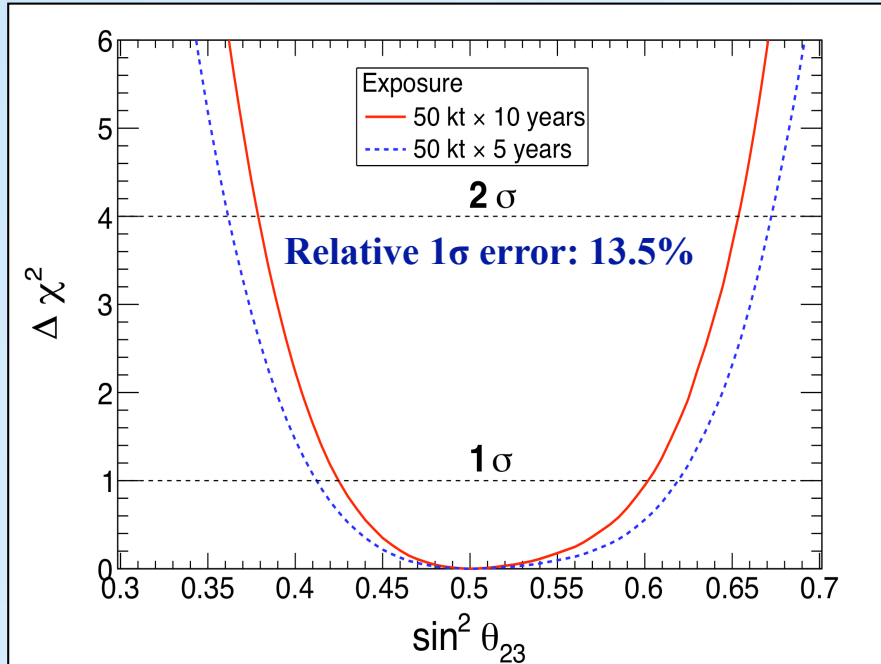

Thakore, Ghosh, Choubey, Dighe, JHEP 1305 (2013) 058

Two Dimensional Muon analysis w/ ICAL resolutions!

Precision complementary to LBL experiments!

Sensitivity comparable to SK with a similar exposure!

3D Analysis including information on Hadrons

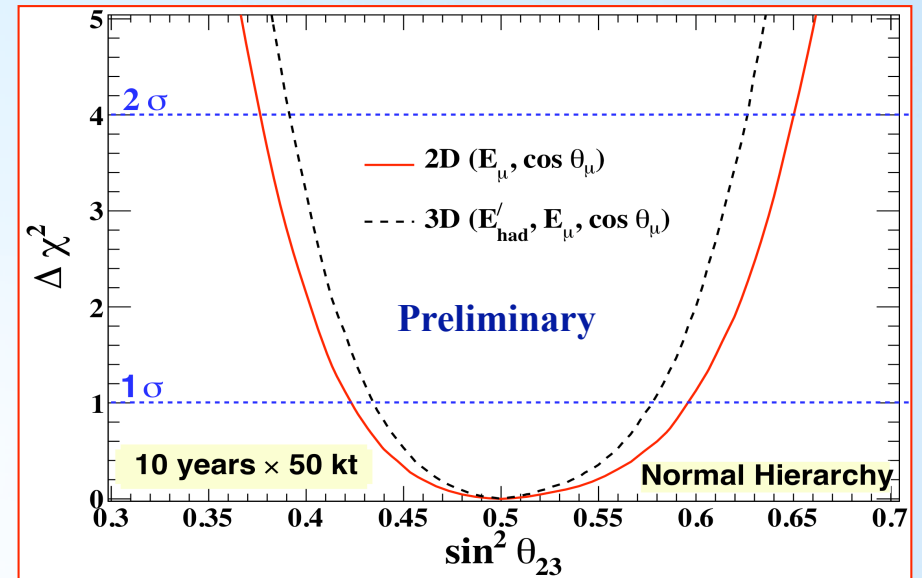
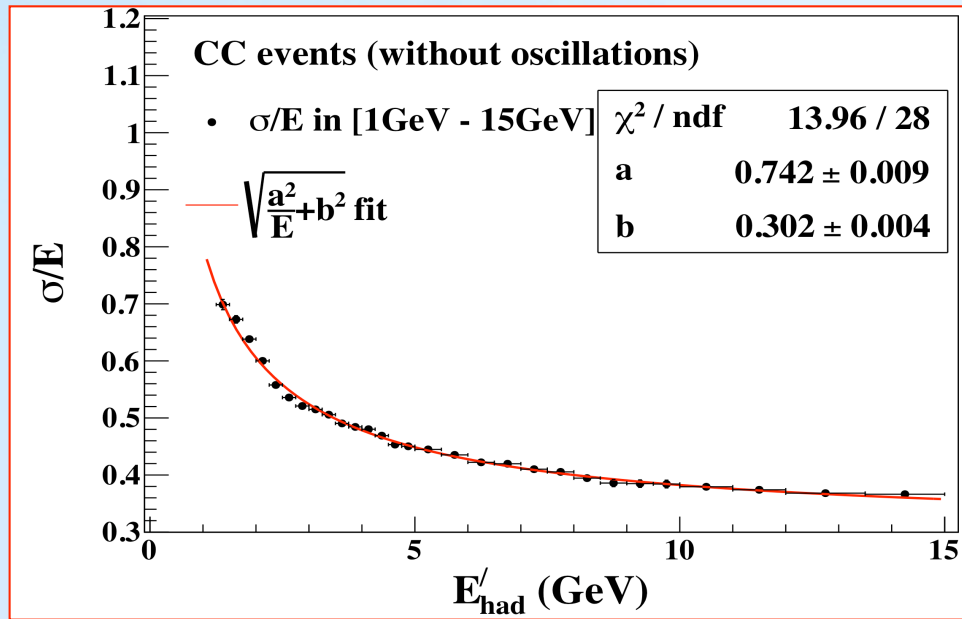

Devi, Ghosh, Kaur, Lakshmi et al., 2013 JINST 8 P11003

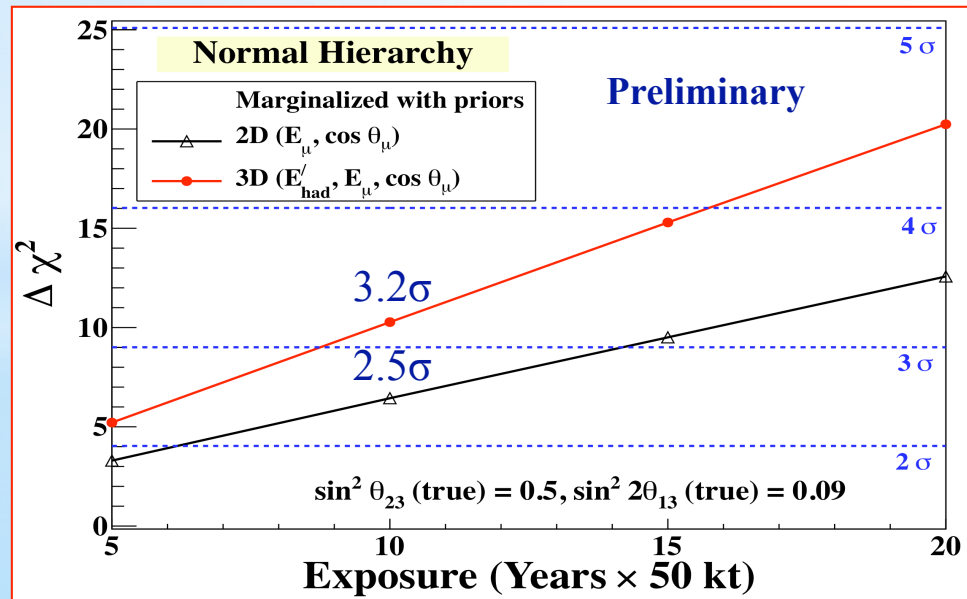

Devi, Thakore et al., in preparation

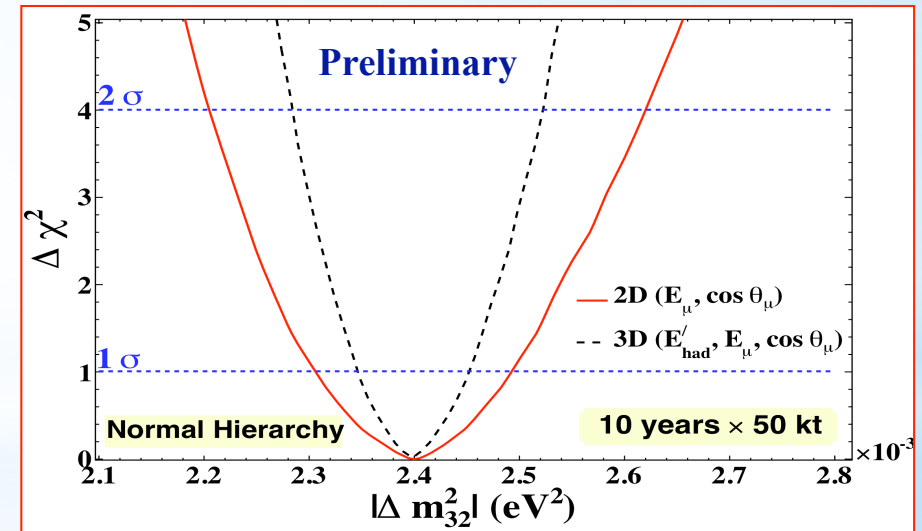

$$E'_h = E_\nu - E_\mu \text{ (from hadron hit calibration)}$$

Significant improvement going from 2D to 3D!

Short term goals and Future Roadmap

- *ICAL-INO Physics White paper w/ detailed Detector Simulation under progress*
- *Building a large 8m X 8m - 20 layer detector with final specifications at Madurai*
- *Magnet & coil design & fabrication, Industrial production of RPCs*
- *Finalize Electronics and DAQ, Pre-project activities at site*

		2012-13	2013-14	2014-15	2015-16	2016-17	2017-18	2018-19
Civil work at Pottipuram								
1	Architectural and Engineering Consultancy	←→						
2	Tendering and award of contracts		←→					
3	Mining of access portal			←→				
4	Excavation of Tunnel			←→				
5	Excavation of caverns				←→			
6	Installation of Services, Cranes, Lifts etc					←→		
7	Surface facilities			←→				
Magnet								
8	Engineering Prototype	←→						
9	Procurement of steel plates		←→					
10	Machining and Transportation				←→			
11	Copper Coils					←→		
12	Assembly/Erection						←→	
Detector/Electronics								
13	Finalization of design details and tendering	←→						
14	Procurement of components		←→					
15	Fabrication and tests of 30000 RPCs			←→				
16	Electronics, Daq, gas handling	←→						
17	Installation and commissioning						←→	

Proposal for a Double Beta Decay Experiment in INO Cavern

The India's TIN detector (Tin.Tin)

<http://www.tifr.res.in/~tin.tin/>

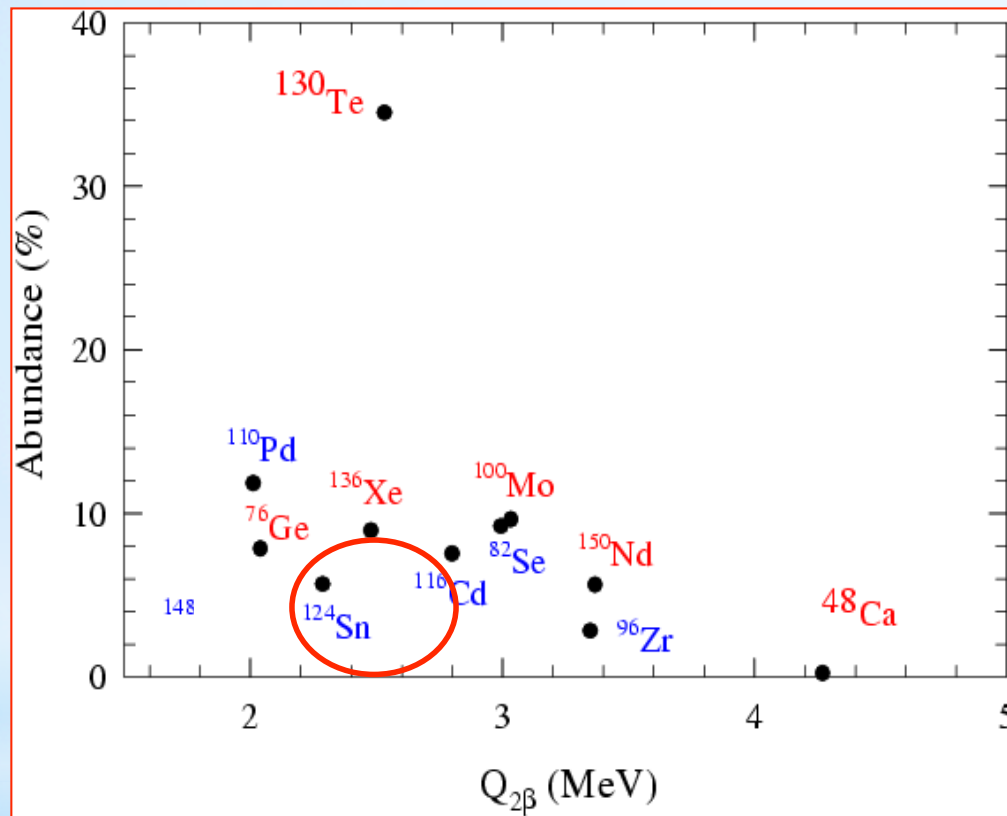

- ^{124}Sn (Tin) Bolometer
- High E resolution
- Q value = 2.28 MeV
- $0\nu\beta\beta$ decay rate $\propto Q^5$
- 5.8% abundance
- Critical temp, $T_C \sim 3.7^\circ \text{K}$
- Reliable NTME calculation
 $Z = 50$ closed shell

- Simple Metallurgy, availability of material, purity
- Electronic specific heat falls off exponentially below T_C
- ^{124}Sn : $T_{1/2} > (0.8 - 1.2) \times 10^{21}$ years, Nucl. Phys. A 807, 269 (2008)

Prototype Development: Work Plan

Joint effort by many institutions in India

TIFR, BARC, VECC, IIT Ropar, Univ. of Lucknow, PRL Ahmedabad

- Make a natural Sn bolometric detector ~ 0.5 to 1 kg
- NTD Ge sensor development
- Detector and background simulation
- Radiation background studies
- Reliable NTME calculations
- Precision Q value measurement ($Q_{\beta\beta} = 2288.1 \pm 1.6$ keV)
- Enrichment of ^{124}Sn
- Constraining NTME
- GT matrix element measurement in NDBD nuclei

Low Temperature Bolometer: A Calorimetric Detector

Energy of particle \rightarrow Thermal energy in detector

\rightarrow measurable temperature rise if *net heat capacity is very low*

Bolometer Schematic

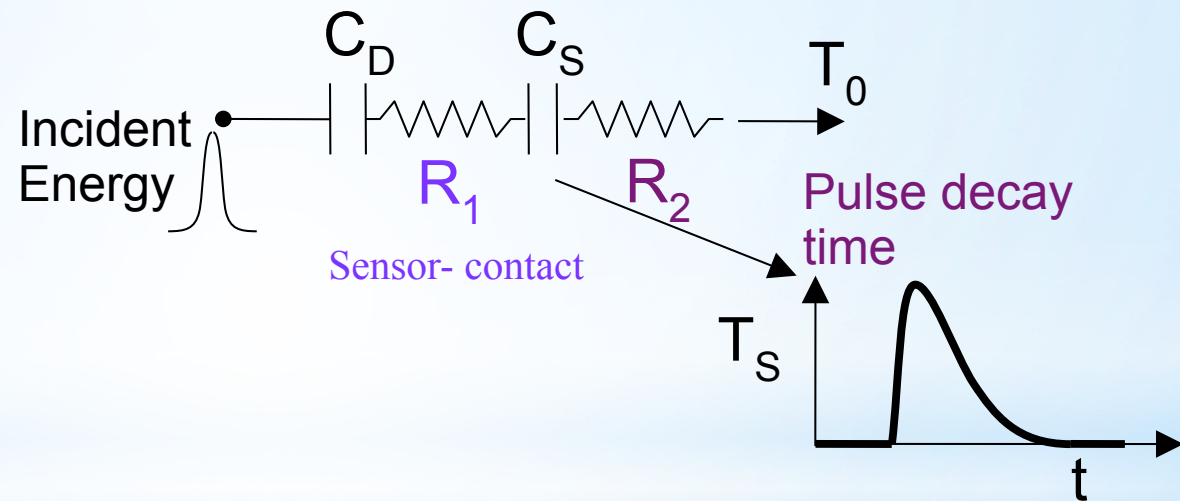
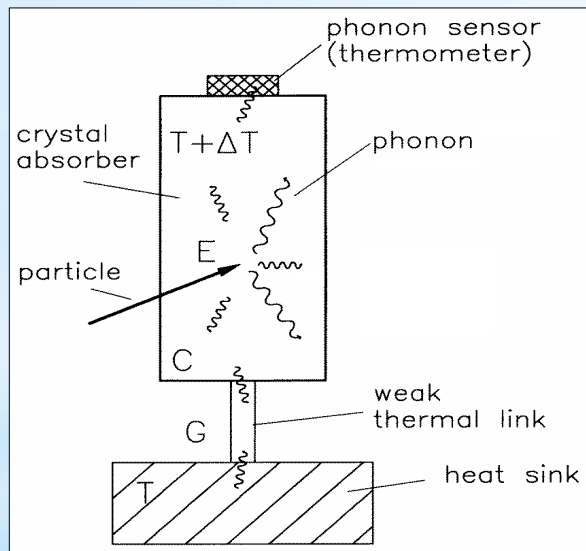

Challenge: to make measurements in time domain at mK temperature

Cryogen free dilution refrigerator installed at TIFR



**cooling power
1.4 mW@120mK**

Base Temp. ~ 7 mK

Future Goal

Build a large scale detector (~ 1 ton) at INO lab
(3phases: 100 kg, 500 kg, 1000 kg)

With 90% enrichment, background ~ 0.01 counts/keV.kg.yr

$m_\nu \sim 50 - 100$ meV in 1 yr

Direct Dark Matter Search in INO Cavern: DINO

Joint effort by many institutions in India & one institute from US

SINP, TEXAS A & M, UCIL, IIT Bombay, IMSc, PRL, BARC, TIFR

Phase1: Prototype: mini-DINO (~ 25 kg), Cost: 1 M\$

- Silicon based cryogenic detector
- At UCIL mine in Jaduguda, depth of 550 m (230 km from Kolkata)
- Sensitivity to low mass WIMPs (spin independent sector)
- Well known and well proven technology
- Easy availability of high purity crystals and low cost
- Fully operational by 2015, First result by 2016

Proposed Silicon Detectors for DINO

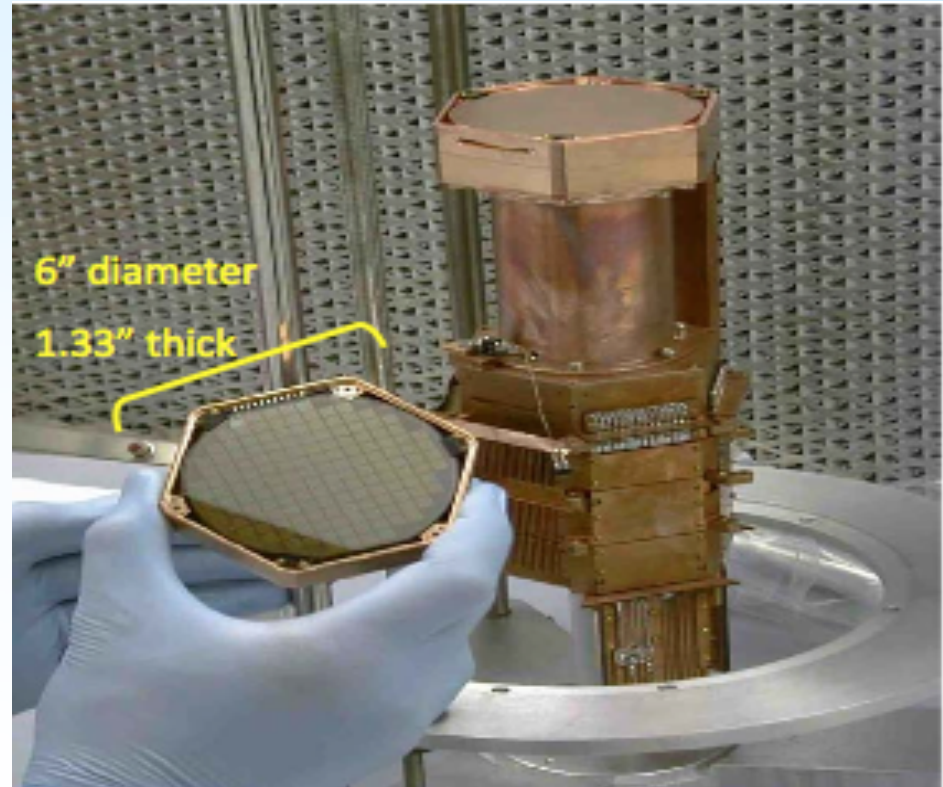
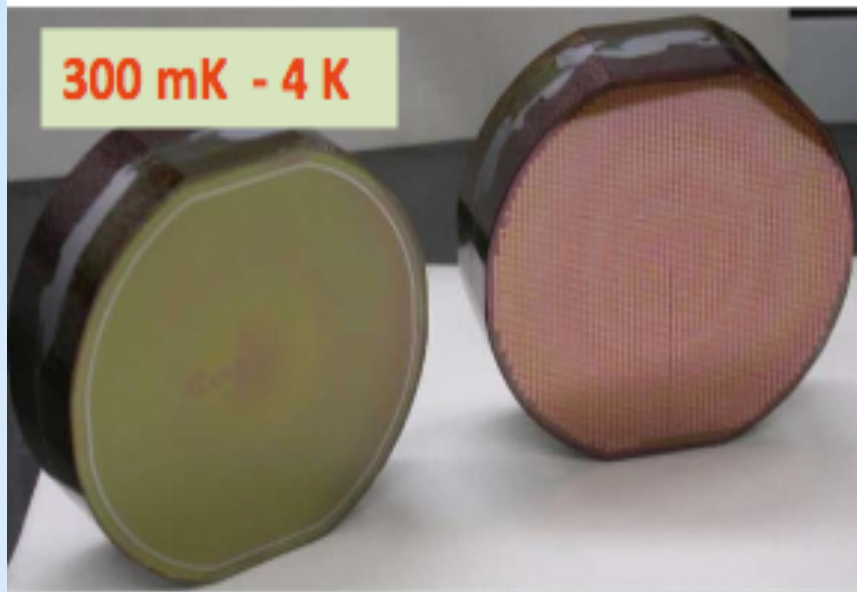

- **Cryogenically cooled Si detectors**
- **Photo lithographically patterned sensors**
- **Low thresholds (~ 10 keV)**
- **Medium energy resolution (~ 1 keV)**
- **3D position determination capability**

Detector Material and Fabrication



wafer etching & polishing

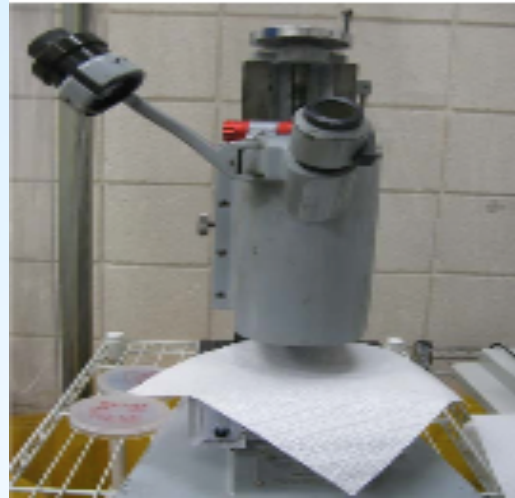

wafer surface inspection



wet chemical etching



sputter deposition

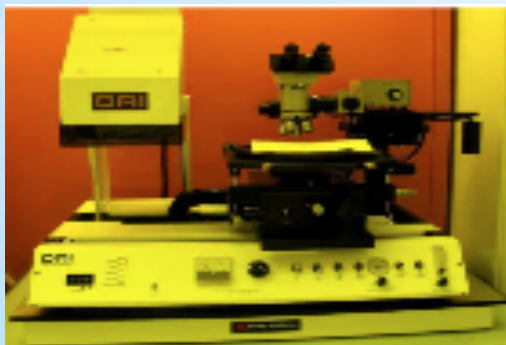

Mask aligner for lithography

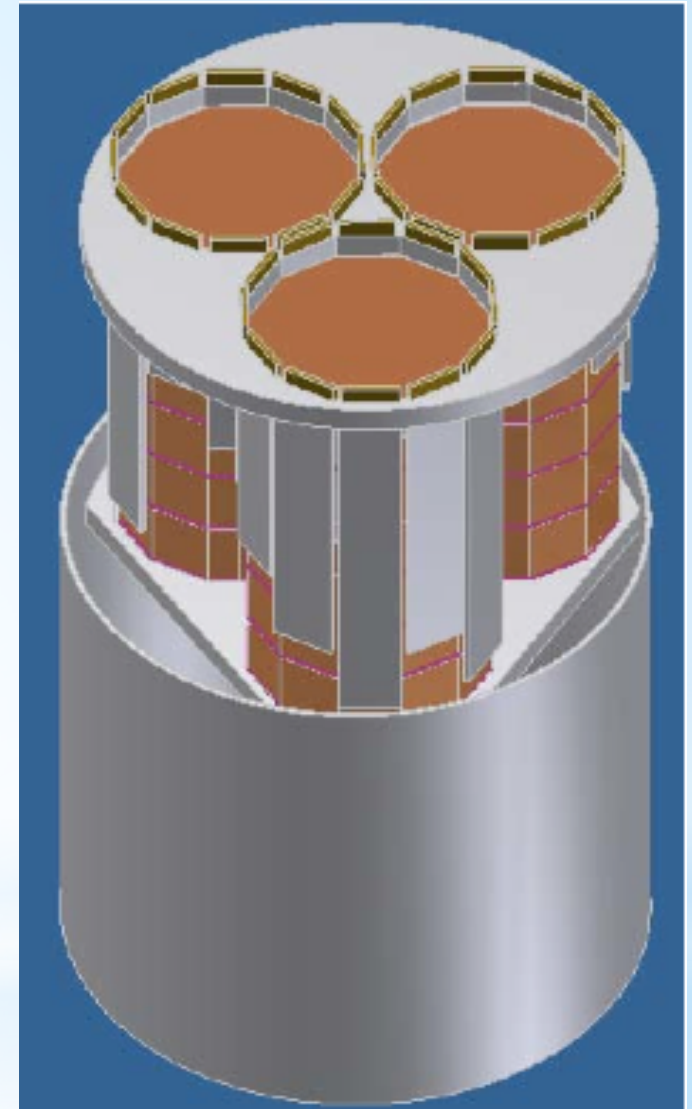
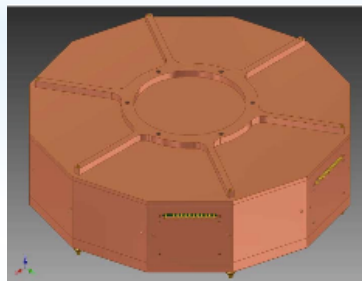

3 towers of 6 detectors each

Future Goal

Ultimate experiment:

**DINO 200 kg phase expected to come up at
INO Site (Cavern-3)**

**Cryostat design will be done as soon as
space allocation & lab infrastructure are frozen**

Participation in FNAL Neutrino Program

- ★ *Involved in MIPP, MINOS+, NOvA, LBNE experiments*
- ★ *At present Nine Collaborating Institutions: 8 in NOvA, 5 in LBNE*
- ★ *12 Faculties from these Institutions are involved in these activities*
- ★ *10 Students already stationed in FNAL, hope to have 25 students by 2018*
- ★ *India is the first country to join LBNE outside United States of America*
- ★ *Indian Institutions in Indo-US neutrino program have proposed to DAE to build Fine Grained Tracker as LBNE near detector*

Concluding Remarks

India is playing a crucial role in neutrino related activities

Huge progress in all fronts in last 2 to 3 years

Strong support from the Community & Funding Agencies

All set to move ahead with the INO mega-science project

International collaboration most welcome

Looking forward for intense activities in the
intensity frontier in India

Thank You!