

Exotic Five-branes

Tetsuji KIMURA

arXiv:1304.4061	Worldsheet
arXiv:1404.5442	Worldvolume
arXiv:1410.8403	Supergravity
arXiv:1503.08635	review

... and so forth

well-known objects
D-branes, NS-branes

String Dualities
→
in lower dimensions

less known objects
Exotic Branes

- ✓ co-dimension **2** (“defect” branes), or less
- ✓ **non**–single-valued metric of spacetime
- ✓ **monodromy** from string dualities

(Exotic) Branes are symbolized as

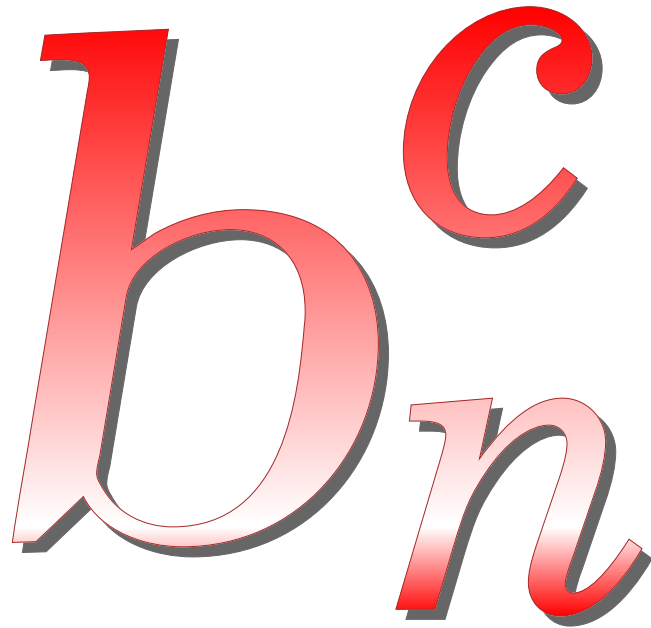
The image shows three large, stylized, red 3D letters: a lowercase 'b' on the left, a lowercase 'c' at the top right, and a lowercase 'n' at the bottom right. The letters have a gradient from dark red to light red and a shadow effect.

b : spatial dimensions

c : # of isometry directions

n : tension $\sim g_s^{-n}$

5_2^2 -brane is constructed from NS5-brane.

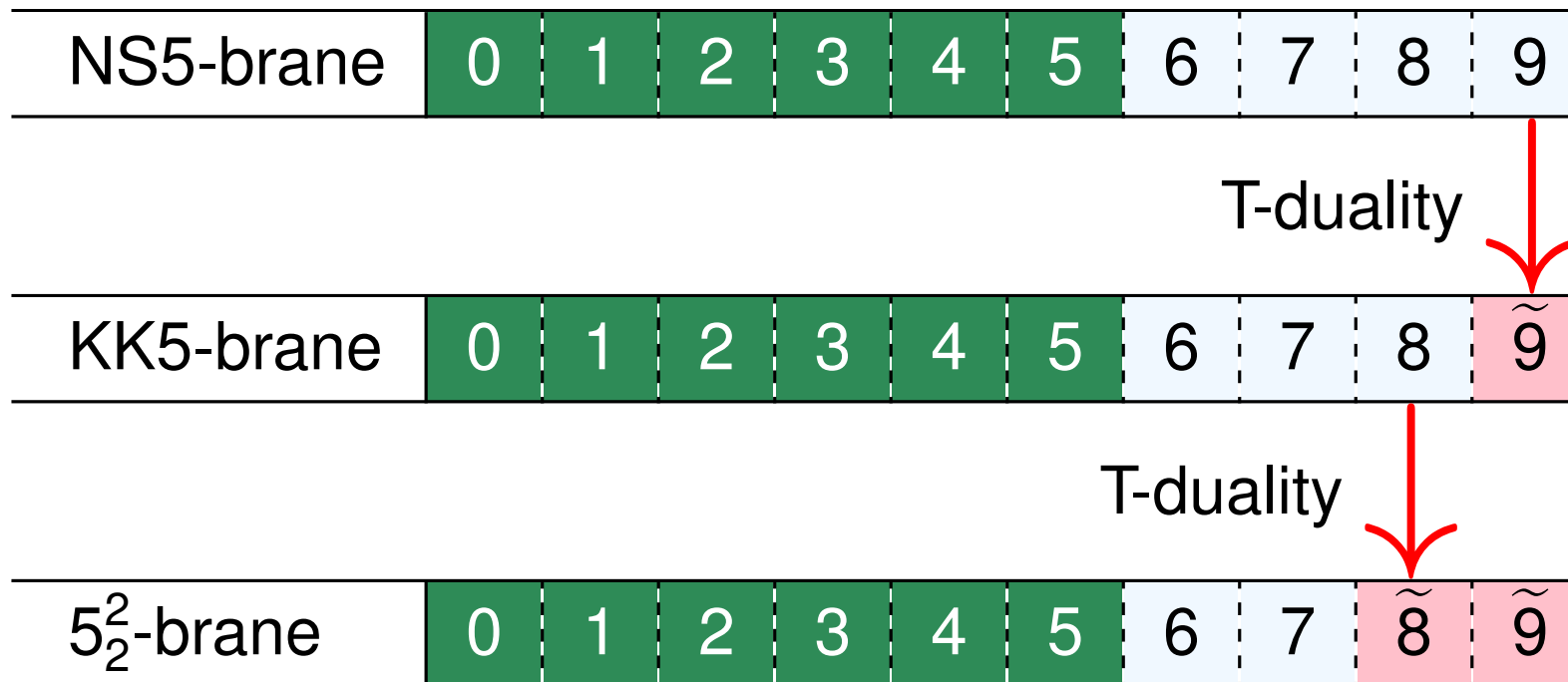

5_2^2 -brane : co-dim. 2

$$ds^2 = dx_{012345}^2 + H [d\varrho^2 + \varrho^2(d\vartheta)^2] + \frac{H}{K} [(d\tilde{x}^8)^2 + (d\tilde{x}^9)^2]$$

$$B_{89} = -\frac{\vartheta}{K}, \quad e^{2\phi} = \frac{H}{K}$$

$$H = 1 + \log \frac{\Lambda}{\varrho}, \quad K = H^2 + \vartheta^2$$

$$\vartheta = 0 : G_{88} = G_{99} = \frac{1}{H}$$

$$\vartheta = 2\pi : G_{88} = G_{99} = \frac{H}{H^2 + (2\pi)^2}$$

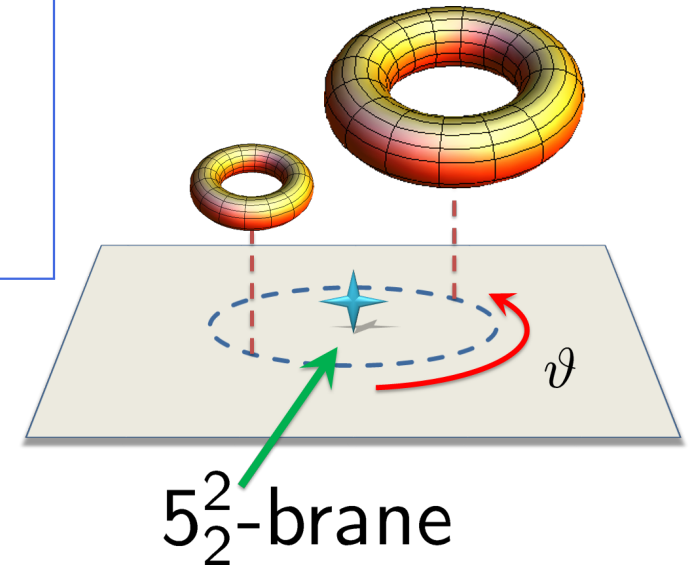

We **never** remove the shift 2π by $\left\{ \begin{array}{l} \text{coordinate transformations,} \\ \text{B-field gauge transformation.} \end{array} \right.$

- ✓ **never** remove the shift 2π by $\left\{ \begin{array}{l} \text{coordinate transformations,} \\ \text{B-field gauge transformation.} \end{array} \right.$
- ✓ ill-defined asymptotic behavior $H = 1 + \log \frac{\Lambda}{\varrho}$

Should we **abandon** it ??

- ✓ **never** remove the shift 2π by $\left\{ \begin{array}{l} \text{coordinate transformations,} \\ \text{B-field gauge transformation.} \end{array} \right.$
- ✓ ill-defined asymptotic behavior $H = 1 + \log \frac{\Lambda}{\varrho}$

Should we **abandon** it ??

No!

“Supergravity limit” is not globally well-defined.

Non-geometric structure

structure group = diffeom. ($GL(d, \mathbb{R})$) + String duality group

$GL(d, \mathbb{R}) \cup$ duality transf.

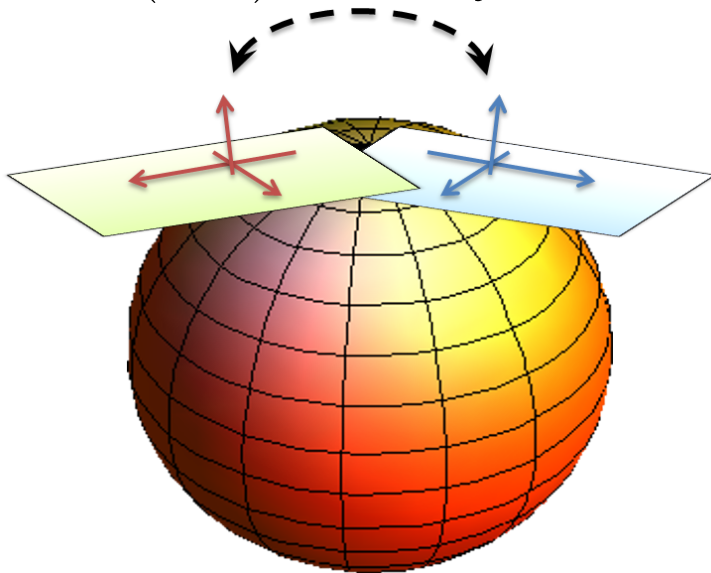

Generalized Geometry	(N. Hitchin)
Doubled Geometry	(C. Hull)

5_2^2 -brane is a **concrete** example (T-fold).
(D7-brane is an example of S-fold.)

Exotic brane shows us a new insight of stringy spacetime

5_2^2 -brane has been analyzed in SUGRA picture.

Ready to study **string worldsheet** picture!



nonlinear sigma model (NLSM)



conformal field theory (CFT)



gauged linear sigma model (GLSM)

Quantum aspects of NLSM/CFT can be traced by **Gauge fields** in GLSM

Indeed, GLSM is the UV completion of string worldsheet theory

GLSM is a powerful tool to explore non-trivial configurations in string theory :
(as the UV completion of string worldsheet theory)

- Calabi-Yau / Landau-Ginzburg
 $\mathcal{N} = (2, 2)$ SUSY
- ALE, ALF spaces (hyper-Kähler) and NS5-branes
 $\mathcal{N} = (4, 4)$ SUSY

In particular, GLSM for ALE/ALF space can be constructed in **brane configuration**.

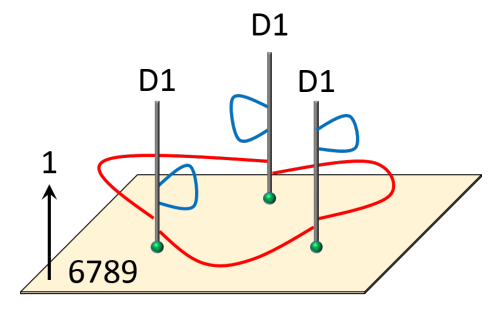
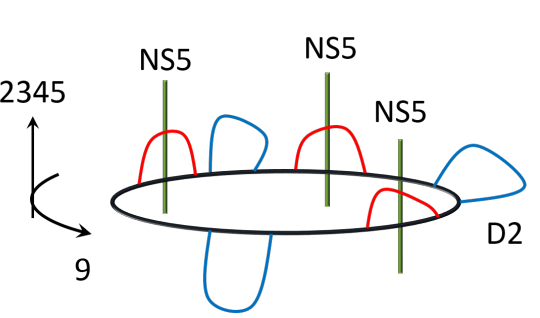

(brane config.?)



GLSM for NS5

GLSM for KK5

GLSM for 5_2^2

Roček-Verlinde

Roček-Verlinde
smearing, winding

IR limit

IR limit

IR limit

NLSM for NS5

NLSM for KK5

NLSM for 5_2^2

Buscher

Buscher

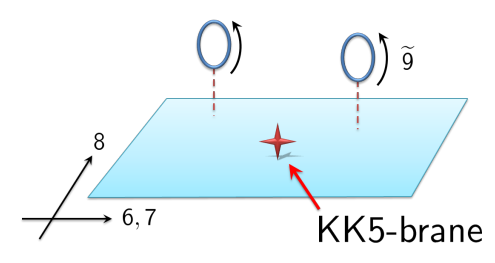
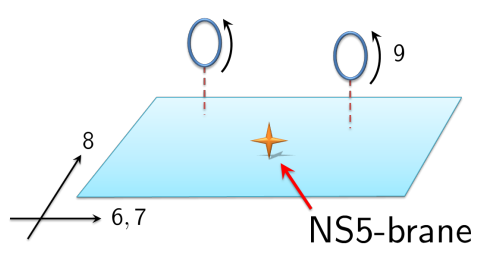

T-duality

T-duality

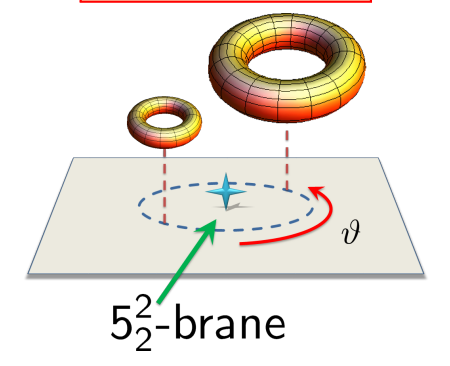

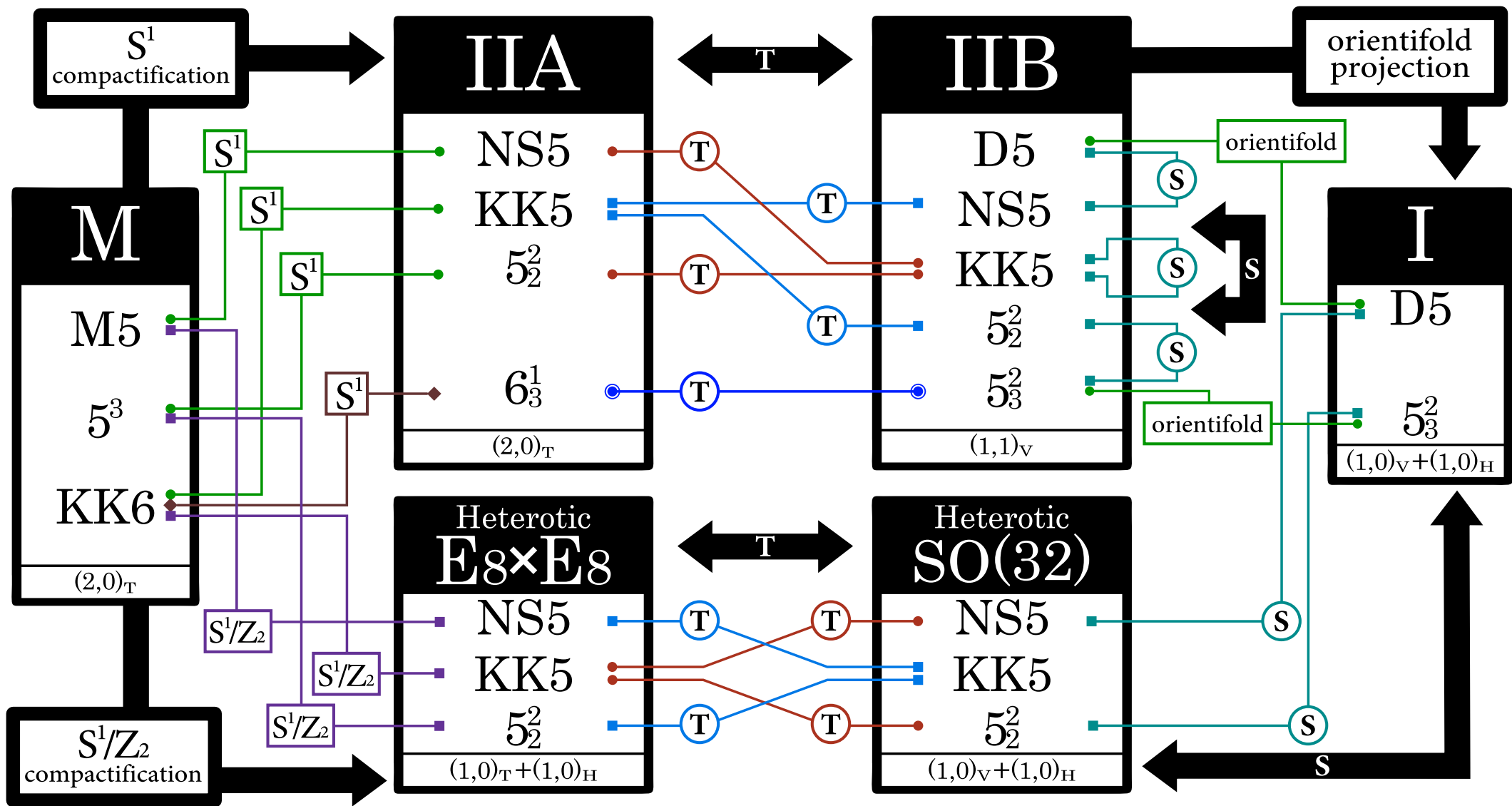

S. Sasaki, M. Yata and TK arXiv:1404.5442

Defect branes in diverse dimensions (codim.2)

D	fundamental $n = 0$	Dirichlet $n = 1$	solitonic $n = 2$	S_D -dual of (Dirichlet) $n = 3$	S_D -dual of (fundamental) $n = 4$
IIB		C_8 [D7]		$E_8 = S_{10}(C_8)$ [7 ₃]	
9		C_7 [D6]		$E_{8,1} = S_9(C_7)$ [6 ₃ ¹]	
8		C_6 [D5]	D_6 [NS5] $D_{7,1}$ [KK5] $D_{8,2}$ [5 ₂ ²]	$E_{8,2} = S_8(C_7)$ [5 ₃ ²]	
7		C_5 [D4]		$E_{8,3} = S_7(C_5)$ [4 ₃ ³]	
6		C_4 [D3]		$E_{8,4} = S_6(C_4)$ [3 ₃ ⁴]	
5		C_3 [D2]		$E_{8,5} = S_5(C_3)$ [2 ₃ ⁵]	
4	B_2 [F1]	C_2 [D1]		$E_{8,6} = S_4(C_2)$ [1 ₃ ⁶]	$F_{8,6} = S_4(B_2)$ [1 ₄ ⁶]
3	[P]	C_1 [D0]		$E_{8,7} = S_3(C_1)$ [0 ₃ ⁷]	$F_{8,7,1}$ [0 ₄ ^(6,1)]

and more...

E.A. Bergshoeff et al arXiv:1009.4657, 1102.0934, 1108.5067, etc.

New objects which we can investigate with fun

The image shows three stylized, red, 3D-rendered letters: 'b', 'c', and 'n'. The letters are arranged with 'b' on the left, 'c' above 'n', and 'n' below 'c'. They have a vertical gradient from dark red at the top to light red at the bottom, and a soft shadow underneath each letter.

Exotic Branes

with SUGRA, NLSM, CFT, GLSM, GG, DG, DFT, EGG, etc.

Thanks

Appendix

NS5-brane (smeared along 9th-direction) G_{MN}, B_{MN}, ϕ

- co-dim. 3 ($\mathbb{R}^3 \times S^1$, $\vec{x} \in \mathbb{R}^3$)
- $ds^2 = dx_{012345}^2 + H \left[(dx^6)^2 + (dx^7)^2 + (dx^8)^2 + (dx^9)^2 \right]$
- $H = 1 + \frac{1}{|\vec{x}|}$
- $H_{mnp} = 3\partial_{[m}B_{np]} = \varepsilon_{mnp}{}^q \partial_q \log H$, $e^{2\phi} = H$

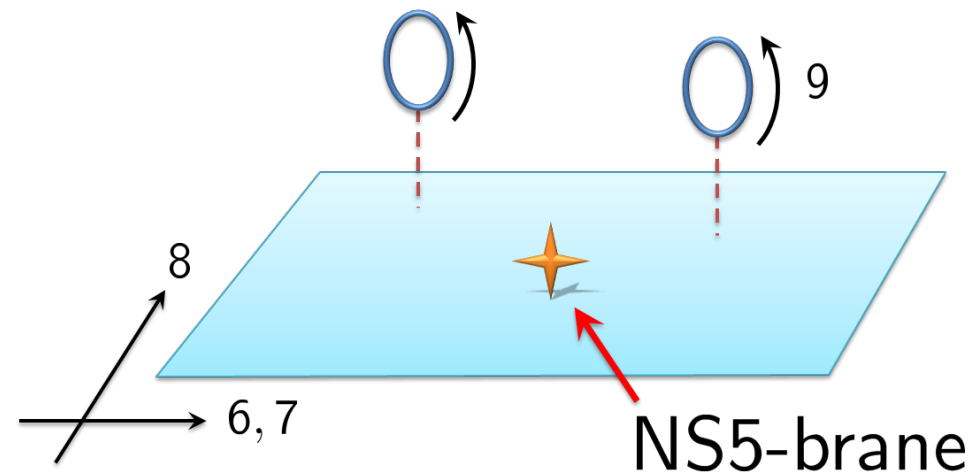

KK5-brane (Taub-NUT space)

$$G_{MN}, \cancel{B_{MN}}, \cancel{\phi}$$

- co-dim. 3 ($\mathbb{R}^3 \times \tilde{S}^1$, $\vec{x} \in \mathbb{R}^3$)
- $ds^2 = dx_{012345}^2 + H \left[(dx^6)^2 + (dx^7)^2 + (dx^8)^2 \right] + \frac{1}{H} (d\tilde{x}^9 - \vec{V} \cdot d\vec{x})^2$
- $H = 1 + \frac{1}{|\vec{x}|}$, $\vec{\nabla} H = \vec{\nabla} \times \vec{V}$
- $H_{mnp} = 0 = \phi$

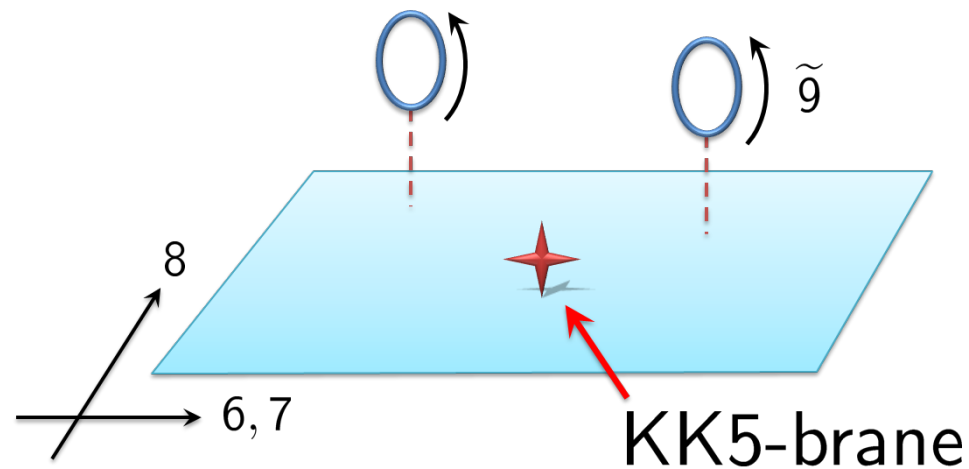

A very rough sketch on D7-brane (co-dim. 2 in 10D)

Moving around a D7-brane induces an $SL(2, \mathbb{Z})$ monodromy charge q

$$q : (C_2, B_2) \rightarrow (C_2 + B_2, B_2)$$

Since co-dim. 2, brane charges are not conserved but

$$(0, \text{NS5}) \rightarrow (\text{D5}, \text{NS5})$$

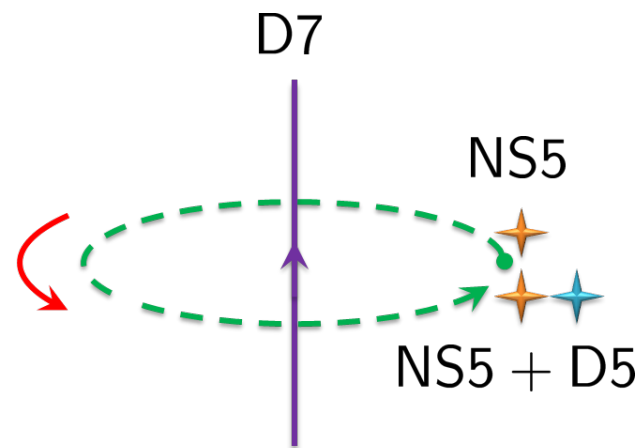

an instructive discussion : J. de Boer and M. Shigemori arXiv:1209.6056

4D asymptotic geometry is locally T^k -fibration over \mathbb{R}^{4-k}

	k	harmonic function	
ALE	(1)	$\frac{1}{ \vec{x} }$	\mathbb{C}^2/Γ with ADE-singularities
ALF	1	$A + \frac{1}{ \vec{x} }$	Taub-NUT
ALG	2	$A + B \log \varrho $	exotic objects such as D7, 5_2^2 , etc.
ALH	3	$A + B r $	linear potential

S.A. Cherkis and A. Kapustin [hep-th/0006050](#), [hep-th/0109141](#)

Brane configuration

M.R. Douglas and G.W. Moore [hep-th/9603167](#)

C.V. Johnson and R.C. Myers [hep-th/9610140](#)

D. Tong [hep-th/0204186](#)

ADE-type singularities in ALE/ALF space can be illustrated as
Affine ADE Dynkin diagram :

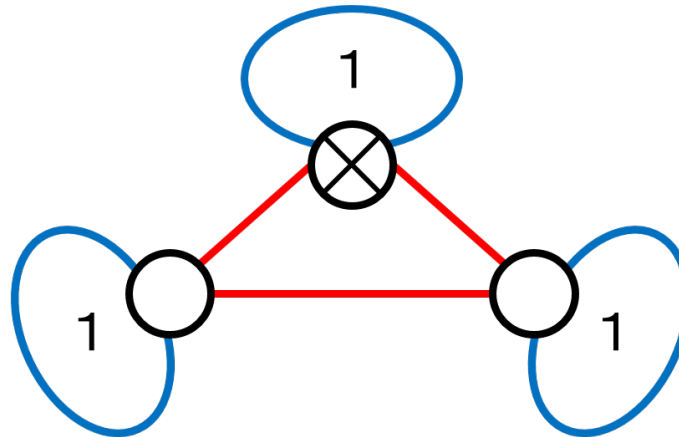

Each Affine ADE Dynkin diagram is mapped (identical) to
ADE quiver diagram.

nodes : gauge groups
blue lines : matters (adjoint repr.)
red lines : matters (bi-fundamental repr.)

The corresponding picture by D-branes is

	0	1	2	3	4	5	6	7	8	(9)
3 KK5	○	○	○	○	○	○	A_2 -ALF			
D1	○	○								

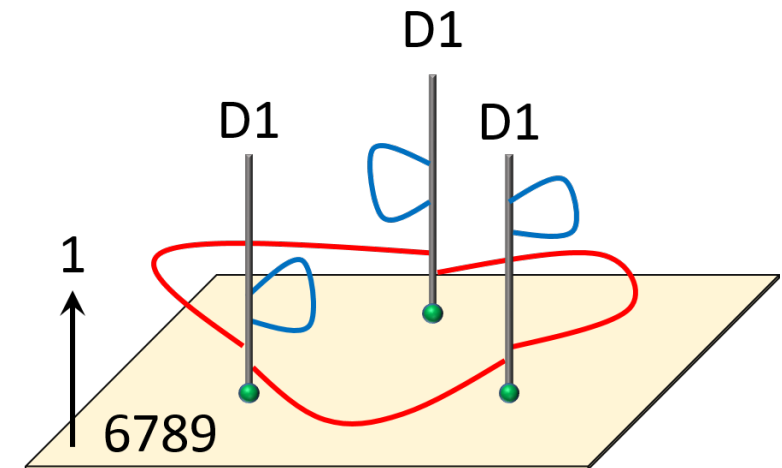

green nodes : singularity points in ALF space
 blue lines : open strings (adjoint repr.)
 red lines : open strings (bi-fundamental repr.)
 6789-plane : ALF space

gauge theory on (compact) D1-branes $\rightarrow \mathcal{N} = (4, 4)$ GLSM for A_2 -ALE/ALF space

(large radius limit of 9th-direction : ALF \rightarrow ALE)

T-duality along 9th-direction :

	0	1	2	3	4	5	6	7	8	(9)
3 NS5	○	○	○	○	○	○	flat			
D2	○	○								○

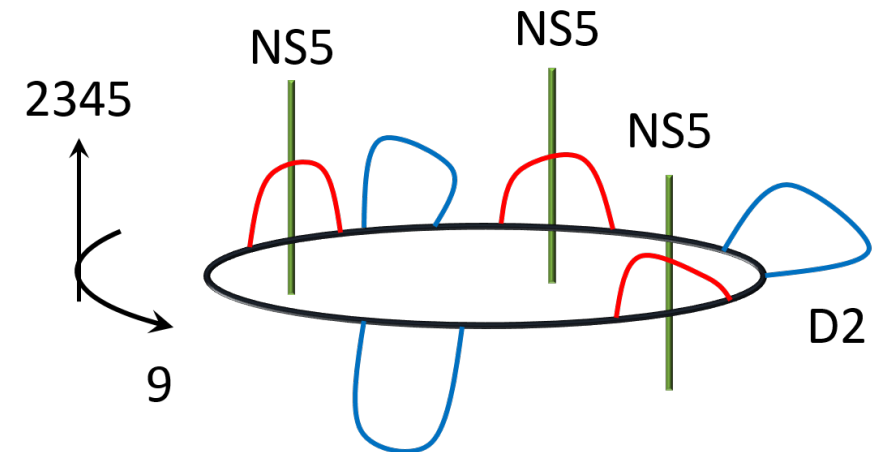

Singularity points in ALE/ALF are mapped to
centers of NS5-branes.

gauge theory on (compact) D2-branes $\rightarrow \mathcal{N} = (4, 4)$ GLSM for NS5-branes

Field contents of 2D $\mathcal{N} = (4, 4)$ GLSM for A_2 -type ALE space :

	$U(1)_1$	$U(1)_2$	$U(1)_3$
$\omega_1 = (a_1, \bar{b}_1)$	+1	-1	0
$\omega_2 = (a_2, \bar{b}_2)$	0	+1	-1
$\omega_3 = (a_3, \bar{b}_3)$	-1	0	+1
(A_m^1, ϕ_1)	adj	-	-
(A_m^2, ϕ_2)	-	adj	-
(A_m^3, ϕ_3)	-	-	adj

$SU(2)$ moment map

$$\vec{\mu}_1 = \omega_1^\dagger \vec{\tau} \omega_1 - \omega_3^\dagger \vec{\tau} \omega_3$$

$$\vec{\mu}_2 = \omega_2^\dagger \vec{\tau} \omega_2 - \omega_1^\dagger \vec{\tau} \omega_1$$

$$\vec{\mu}_3 = \omega_3^\dagger \vec{\tau} \omega_3 - \omega_2^\dagger \vec{\tau} \omega_2$$

$$0 = \vec{\mu}_1 + \vec{\mu}_2 + \vec{\mu}_3$$

Hyper-Kähler quotient construction

cf.) reconstruction by toric data: M. Yata and TK arXiv:1402.5580

Field contents of 2D $\mathcal{N} = (4, 4)$ GLSM for A_2 -type **ALF** space :

	$U(1)_1$	$U(1)_2$	$U(1)_3$	$U(1)_F$
$\omega_1 = (a_1, \bar{b}_1)$	+1	-1	0	+1
$\omega_2 = (a_2, \bar{b}_2)$	0	+1	-1	+1
$\omega_3 = (a_3, \bar{b}_3)$	-1	0	+1	+1
(A_m^1, ϕ_1)	adj	-	-	-
(A_m^2, ϕ_2)	-	adj	-	-
(A_m^3, ϕ_3)	-	-	adj	-
(X^6, X^7, X^8)	neutral			
(A_m^F, ϕ_F)	-	-	-	adj

$SU(2)$ moment map

$$\vec{\mu}_1 = \omega_1^\dagger \vec{\tau} \omega_1 - \omega_3^\dagger \vec{\tau} \omega_3$$

$$\vec{\mu}_2 = \omega_2^\dagger \vec{\tau} \omega_2 - \omega_1^\dagger \vec{\tau} \omega_1$$

$$\vec{\mu}_3 = \omega_3^\dagger \vec{\tau} \omega_3 - \omega_2^\dagger \vec{\tau} \omega_2$$

$$0 = \vec{\mu}_1 + \vec{\mu}_2 + \vec{\mu}_3$$

$$\vec{\mu}_F = \sum_{i=1}^3 \omega_i^\dagger \vec{\tau} \omega_i - \vec{X}$$

Diagonalize $U(1)_{i,F} \rightarrow$ [D. Tong hep-th/0204186](#)

Duality transformations with **F**-term

in $\mathcal{N} = (2, 2)$ framework

Duality : chiral Ψ \longleftrightarrow twisted chiral Y

Target space geometry is T-dualized under the above transformation.

Duality : chiral Ψ \longleftrightarrow twisted chiral Y

Target space geometry is T-dualized under the above transformation.

- ▶ dualize **neutral** chiral in D-term (ex. torus)

$$\int d^4\theta |\Psi|^2 \leftrightarrow \int d^4\theta \left[\frac{1}{2}R^2 - R(Y + \bar{Y}) \right] \leftrightarrow - \int d^4\theta |Y|^2$$

- ▶ dualize **charged** chiral in D-term (ex. projective space)

$$\int d^4\theta |\Psi|^2 e^{2V} \leftrightarrow \int d^4\theta \left[e^{2V+R} - R(Y + \bar{Y}) \right] \leftrightarrow - \int d^4\theta (Y + \bar{Y}) \left[\log(Y + \bar{Y}) - 2V \right]$$

These are well established.

“Global symmetry” $\Psi + \alpha$ (or $e^{i\alpha} \Psi$) is preserved in D-term, but broken in F-term.

— Make sense? —

- ▶ dualize **neutral / charged** chiral in D-term and **F**-term

They can be interpreted as T-duality transformations under conversion from **F**-term to D-term with trick(es).

- Dualize **neutral** chiral in D-term and **F**-term

$$\mathcal{L}_1 = \int d^4\theta |\Psi|^2 + \left\{ \int d^2\theta \Psi \mathcal{W}(\Phi) + (\text{h.c.}) \right\}$$

1. Convert **F**-term to D-term via $\mathcal{W} = \bar{D}_+ \bar{D}_- C$:

$$\int d^2\theta \Psi \mathcal{W} + (\text{h.c.}) = \int d^4\theta \left[(\Psi + \bar{\Psi})(C + \bar{C}) + (\Psi - \bar{\Psi})(C - \bar{C}) \right]$$

2. Replace $\Psi \pm \bar{\Psi}$ to auxiliary fields R and iS :

$$\mathcal{L}_2 = \int d^4\theta \left[\frac{1}{2} R^2 + R(C + \bar{C}) + iS(C - \bar{C}) - R(Y + \bar{Y}) - iS(\Upsilon - \bar{\Upsilon}) \right]$$

3. Integrating out R and Υ , we obtain the “dual” system :

$$\mathcal{L}_3 = \int d^4\theta \left[-\frac{1}{2} \left((Y + \bar{Y}) + (C + \bar{C}) \right)^2 + (\Psi - \bar{\Psi})(C - \bar{C}) \right]$$

Instead, integrate out Y and $\Upsilon \rightarrow \mathcal{L}_1$ appears

- Dualize **charged** chiral in D-term and **F**-term

$$\mathcal{L}_4 = \int d^4\theta |\Psi|^2 e^{2V} + \left\{ \int d^2\theta \Psi \mathcal{W}(\Phi) + (\text{h.c.}) \right\}$$

1. Convert **F**-term to D-term via $\mathcal{W} = \bar{D}_+ \bar{D}_- C$:

$$\int d^2\theta \Psi \mathcal{W} + (\text{h.c.}) = 2 \int d^4\theta \left[\Psi C + \bar{\Psi} \bar{C} \right]$$

2. Replace $\Psi \pm \bar{\Psi}$ to auxiliary fields R and iS :

$$\mathcal{L}_5 = \int d^4\theta \left[e^{2V+R} + 2 \left\{ e^{\frac{1}{2}(R+iS)} C + e^{\frac{1}{2}(R-iS)} \bar{C} \right\} - R(Y + \bar{Y}) - iS(\Upsilon - \bar{\Upsilon}) \right]$$

3. Integrating out R and Υ , we obtain the “dual” system :

$$\mathcal{L}_6 = \int d^4\theta \left[-2(Y + \bar{Y}) \log \mathcal{F} + \frac{1}{2} \mathcal{F} \mathcal{T} + 2V(Y + \bar{Y}) \right]$$

$$\mathcal{F} = -\mathcal{T} + \sqrt{\mathcal{T}^2 + 4(Y + \bar{Y})}, \quad \mathcal{T} = e^{-V} \left[e^{+\frac{1}{2}(\Omega - \bar{\Omega})} C + e^{-\frac{1}{2}(\Omega - \bar{\Omega})} \bar{C} \right], \quad \Psi = e^{\Omega}$$

$\Psi - \bar{\Psi}$ still remains **after** the transformation.

The existence is rather important to complete the Duality transformations.

$\Psi - \bar{\Psi}$ appears as an auxiliary field, which **must be removed** finally.

Indeed, the procedure “**integrating-out of $\Psi - \bar{\Psi}$** ” leads to
the correct involution of the dual fields in the system !

$e^{\Omega - \bar{\Omega}}$ still remains **after** the transformation.

The existence is rather important to complete the Duality transformations.

$e^{\Omega - \bar{\Omega}}$ appears as an auxiliary field, which **must be removed** finally.

Indeed, the procedure “**integrating-out of $e^{\Omega - \bar{\Omega}}$** ” leads to the correct involution of the dual fields in the system !

GLSM for five-branes

NS5-branes, KK5-branes and exotic 5_2^2 -brane

(w/ 2D $\mathcal{N} = (2, 2)$ superfields)

NS5-brane

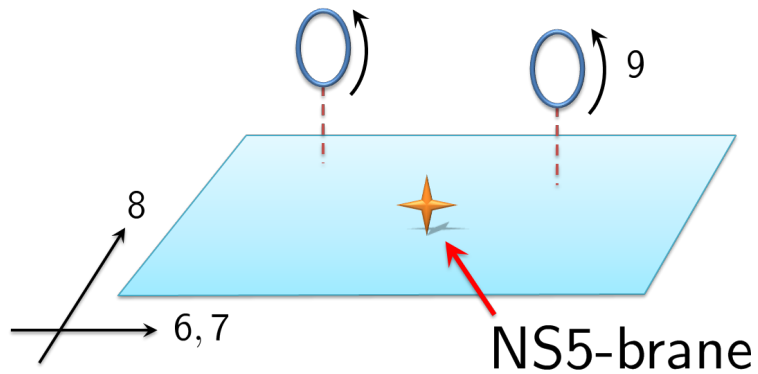

$$\begin{aligned}
 \mathcal{L} = & \int d^4\theta \left\{ \frac{1}{e^2} (|\Phi|^2 - |\Sigma|^2) + |Q|^2 e^{+2V} + |\tilde{Q}|^2 e^{-2V} \right\} \\
 & + \frac{1}{g^2} \int d^4\theta \left\{ |\Psi|^2 - |\Theta|^2 \right\} \\
 & + \left\{ \int d^2\theta \left(-\tilde{Q}\Phi Q + (s - \Psi)\Phi \right) + (\text{h.c.}) \right\} \\
 & + \left\{ \int d^2\tilde{\theta} \left((t - \Theta)\Sigma \right) + (\text{h.c.}) \right\}
 \end{aligned}$$

$$X^6 + iX^8 \in \Psi \text{ (chiral)}, \quad X^7 + iX^9 \in \Theta \text{ (twisted chiral)}$$

D. Tong [hep-th/0204186](https://arxiv.org/abs/hep-th/0204186)

NS5-brane

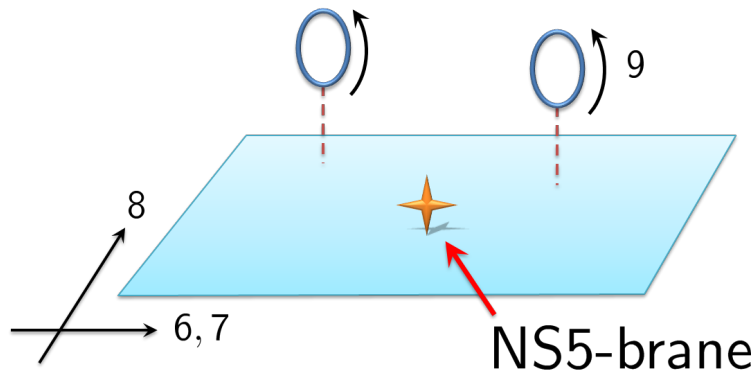

$$\begin{aligned}
 \mathcal{L} = & \int d^4\theta \left\{ \frac{1}{e^2} (|\Phi|^2 - |\Sigma|^2) + |Q|^2 e^{+2V} + |\tilde{Q}|^2 e^{-2V} \right\} \\
 & + \frac{1}{g^2} \int d^4\theta \left\{ |\Psi|^2 - |\Theta|^2 \right\} \\
 & + \left\{ \int d^2\theta \left(-\tilde{Q}\Phi Q + (s - \Psi)\Phi \right) + (\text{h.c.}) \right\} \\
 & + \left\{ \int d^2\tilde{\theta} \left((t - \Theta)\Sigma \right) + (\text{h.c.}) \right\}
 \end{aligned}$$

$$X^6 + iX^8 \in \Psi \text{ (chiral)}, \quad X^7 + iX^9 \in \Theta \text{ (twisted chiral)}$$

Position is labelled by FI parameters (s, t)

IR limit \rightarrow gauge multiplets are integrated out \rightarrow NLSM on NS5-brane geometry

$$\mathcal{L}_{\text{NS5}}^{\text{NLMS}} = -\frac{H}{2} \left[(\partial_m \vec{X})^2 + (\partial_m X^9)^2 \right] + \varepsilon^{mn} \Omega_i \partial_m X^i \partial_n X^9$$

Target space geometry is

$$\begin{aligned} G_{IJ} &= H \delta_{IJ} & B_{i9} &= \Omega_i \\ H &= \frac{1}{g^2} + \frac{1}{|\vec{X}|} & \nabla_i H &= (\nabla \times \Omega)_i \end{aligned}$$

Quantum corrections can be traced by [vortex](#) corrections of 2D gauge fields.

NS5-brane

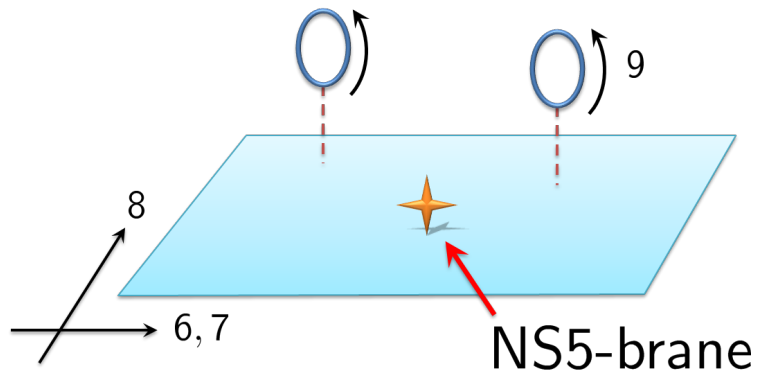

$$\begin{aligned}
 \mathcal{L} = & \int d^4\theta \left\{ \frac{1}{e^2} (|\Phi|^2 - |\Sigma|^2) + |Q|^2 e^{+2V} + |\tilde{Q}|^2 e^{-2V} \right\} \\
 & + \frac{1}{g^2} \int d^4\theta \left\{ |\Psi|^2 - |\Theta|^2 \right\} \\
 & + \left\{ \int d^2\theta \left(-\tilde{Q}\Phi Q + (s - \Psi)\Phi \right) + (\text{h.c.}) \right\} \\
 & + \left\{ \int d^2\tilde{\theta} \left((t - \Theta)\Sigma \right) + (\text{h.c.}) \right\}
 \end{aligned}$$

$$X^6 + iX^8 \in \Psi \text{ (chiral)}, \quad X^7 + iX^9 \in \Theta \text{ (twisted chiral)}$$

Dualize the neutral twisted chiral $\Theta \rightarrow \Gamma$: T-duality along 9th-direction

T-duality transformations

(free) string	sign flip (parity) in right-mover	momentum \leftrightarrow winding
spacetime	Buscher rule	$(G_{IJ}, B_{IJ}, \phi) \leftrightarrow (G'_{IJ}, B'_{IJ}, \phi')$
SUSY sigma model	Roček-Verlinde formula	chiral \leftrightarrow twisted chiral

KK5-brane

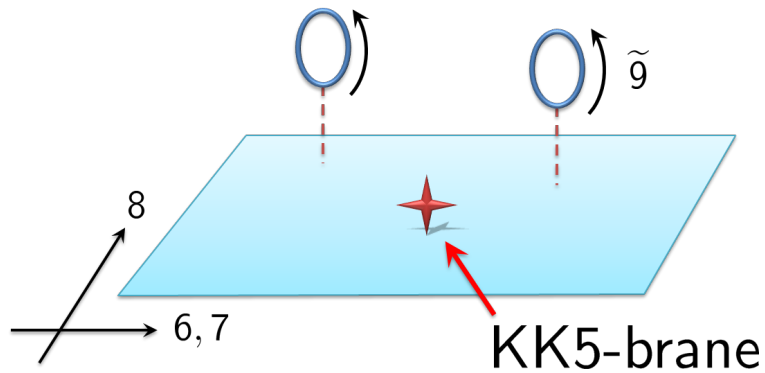

$$\begin{aligned}
 \mathcal{L} = & \int d^4\theta \left\{ \frac{1}{e^2} (|\Phi|^2 - |\Sigma|^2) + |Q|^2 e^{+2V} + |\tilde{Q}|^2 e^{-2V} \right\} \\
 & + \int d^4\theta \left\{ \frac{1}{g^2} |\Psi|^2 + \frac{g^2}{2} (\Gamma + \bar{\Gamma} + V)^2 \right\} \\
 & + \left\{ \int d^2\theta \left(-\tilde{Q}\Phi Q + (s - \Psi)\Phi \right) + (\text{h.c.}) \right\} \\
 & + \left\{ \int d^2\tilde{\theta} (t\Sigma) + (\text{h.c.}) \right\} + \varepsilon^{mn} \partial_m (X^9 A_n)
 \end{aligned}$$

$$X^6 + iX^8 \in \Psi \text{ (chiral)}, \quad X^7 + i\tilde{X}^9 \in \Gamma \text{ (chiral)}$$

D. Tong [hep-th/0204186](https://arxiv.org/abs/hep-th/0204186)

KK5-brane

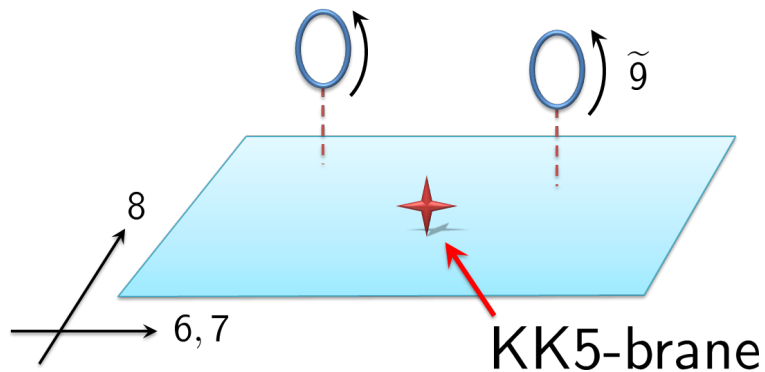

$$\begin{aligned}
 \mathcal{L} = & \int d^4\theta \left\{ \frac{1}{e^2} (|\Phi|^2 - |\Sigma|^2) + |Q|^2 e^{+2V} + |\tilde{Q}|^2 e^{-2V} \right\} \\
 & + \int d^4\theta \left\{ \frac{1}{g^2} |\Psi|^2 + \frac{g^2}{2} (\Gamma + \bar{\Gamma} + V)^2 \right\} \\
 & + \left\{ \int d^2\theta \left(-\tilde{Q}\Phi Q + (s - \Psi)\Phi \right) + (\text{h.c.}) \right\} \\
 & + \left\{ \int d^2\tilde{\theta} (t\Sigma) + (\text{h.c.}) \right\} + \varepsilon^{mn} \partial_m (X^9 A_n)
 \end{aligned}$$

$$X^6 + iX^8 \in \Psi \text{ (chiral)}, \quad X^7 + i\tilde{X}^9 \in \Gamma \text{ (chiral)}$$

Position is labelled by FI parameters (s, t)

IR limit \rightarrow gauge multiplets are integrated out \rightarrow NLSM on KK5-branes (ALF)

$$\mathcal{L}_{\text{KK5}}^{\text{NLSM}} = -\frac{H}{2}(\partial_m \vec{X})^2 - \frac{1}{2H}(\partial_m \tilde{X}^9 - \Omega_i \partial_m X^i)^2$$

$$+ \varepsilon^{mn} \partial_m ((X^9 - t^9) A_n)$$

Target space geometry is

$$G_{IJ} = \text{Taub-NUT} \quad B_{i9} = 0$$

$$H = \frac{1}{g^2} + \frac{1}{|\vec{X}|} \quad \nabla_i H = (\nabla \times \Omega)_i$$

Quantum corrections can be traced by [vortex](#) corrections of 2D gauge fields.

KK5-brane

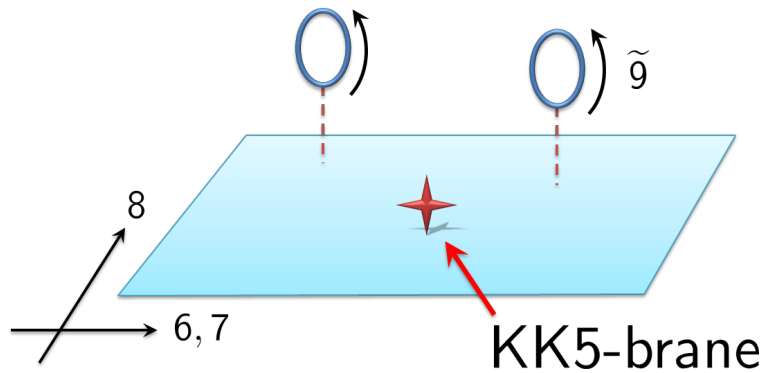

$$\begin{aligned}
 \mathcal{L} = & \int d^4\theta \left\{ \frac{1}{e^2} (|\Phi|^2 - |\Sigma|^2) + |Q|^2 e^{+2V} + |\tilde{Q}|^2 e^{-2V} \right\} \\
 & + \int d^4\theta \left\{ \frac{1}{g^2} |\Psi|^2 + \frac{g^2}{2} (\Gamma + \bar{\Gamma} + V)^2 \right\} \\
 & + \left\{ \int d^2\theta \left(-\tilde{Q}\Phi Q + (s - \Psi)\Phi \right) + (\text{h.c.}) \right\} \\
 & + \left\{ \int d^2\tilde{\theta} (t\Sigma) + (\text{h.c.}) \right\} + \varepsilon^{mn} \partial_m (X^9 A_n)
 \end{aligned}$$

$$X^6 + iX^8 \in \Psi \text{ (chiral)}, \quad X^7 + i\tilde{X}^9 \in \Gamma \text{ (chiral)}$$

Dualize the neutral chiral $\Psi \rightarrow \Xi$: T-duality along 8th-direction

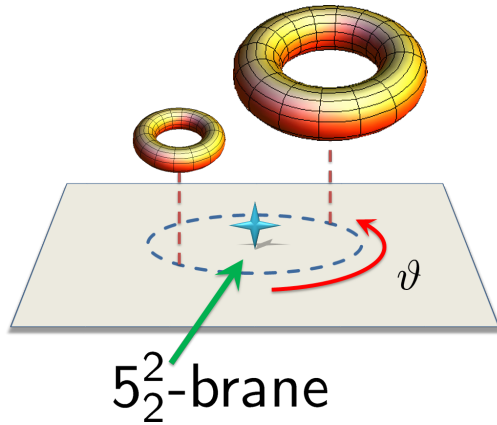

$$\begin{aligned}
 \mathcal{L} = & \int d^4\theta \left\{ \frac{1}{e^2} (|\Phi|^2 - |\Sigma|^2) + |Q|^2 e^{+2V} + |\tilde{Q}|^2 e^{-2V} \right\} \\
 & + \int d^4\theta \left\{ -\frac{g^2}{2} (\Xi + \bar{\Xi} - (C + \bar{C}))^2 + \frac{g^2}{2} (\Gamma + \bar{\Gamma} + V)^2 \right\} \\
 & + \left\{ \int d^2\theta \left(-\tilde{Q}\Phi Q + s\Phi \right) + (\text{h.c.}) \right\} - \int d^4\theta (\Psi - \bar{\Psi})(C - \bar{C}) \\
 & + \left\{ \int d^2\tilde{\theta} (t\Sigma) + (\text{h.c.}) \right\} + \varepsilon^{mn} \partial_m (X^9 A_n)
 \end{aligned}$$

$$X^6 + i\tilde{X}^8 \in \Xi \text{ (twisted chiral)}, \quad X^7 + i\tilde{X}^9 \in \Gamma \text{ (chiral)}$$

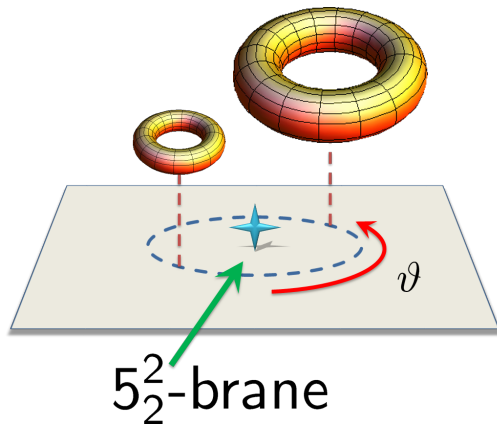

$$\begin{aligned}
 \mathcal{L} = & \int d^4\theta \left\{ \frac{1}{e^2} (|\Phi|^2 - |\Sigma|^2) + |Q|^2 e^{+2V} + |\tilde{Q}|^2 e^{-2V} \right\} \\
 & + \int d^4\theta \left\{ -\frac{g^2}{2} (\Xi + \bar{\Xi} - (C + \bar{C}))^2 + \frac{g^2}{2} (\Gamma + \bar{\Gamma} + V)^2 \right\} \\
 & + \left\{ \int d^2\theta \left(-\tilde{Q}\Phi Q + s\Phi \right) + (\text{h.c.}) \right\} - \int d^4\theta (\Psi - \bar{\Psi})(C - \bar{C}) \\
 & + \left\{ \int d^2\tilde{\theta} (t\Sigma) + (\text{h.c.}) \right\} + \varepsilon^{mn} \partial_m (X^9 A_n)
 \end{aligned}$$

$$X^6 + i\tilde{X}^8 \in \Xi \text{ (twisted chiral)}, \quad X^7 + i\tilde{X}^9 \in \Gamma \text{ (chiral)}$$

$\Psi - \bar{\Psi}$ is no longer dynamical \rightarrow $\begin{cases} \Xi + \bar{\Xi} : & \text{momentum modes} \\ \Psi - \bar{\Psi} : & \text{winding modes!} \end{cases}$

IR limit \rightarrow gauge multiplets are integrated out
 Further, integrate out $\Psi - \bar{\Psi}$: Exotic Five-brane!

From GLSM to NLSM

LESSON 1 : GLSM for NS5-brane

D. Tong [hep-th/0204186](#)

J.A. Harvey and S. Jensen [hep-th/0507204](#)

K. Okuyama [hep-th/0508097](#)

Bosonic Lagrangian after integrating-out auxiliary fields :

$$\mathcal{L}_{\text{NS5}}^{\text{kin}} = \frac{1}{e^2} \left[\frac{1}{2} (F_{01})^2 - |\partial_m \sigma|^2 - |\partial_m \phi|^2 \right] - \left[|D_m q|^2 + |D_m \tilde{q}|^2 \right] \\ - \frac{1}{2g^2} \left[(\partial_m X^6)^2 + (\partial_m X^7)^2 + (\partial_m X^8)^2 + (\partial_m X^9)^2 \right] + (X^9 - t^9) F_{01}$$

$$\mathcal{L}_{\text{NS5}}^{\text{pot}} = -2(|\sigma|^2 + |\phi|^2)(|q|^2 + |\tilde{q}|^2 + g^2) \\ - \frac{e^2}{2} \left(|q|^2 - |\tilde{q}|^2 - (X^7 - t^7) \right)^2 - e^2 \left| q\tilde{q} + (X^6 - s^6) + i(X^8 - s^8) \right|^2$$

Steps to NLSM for NS5-brane

1. SUSY vacua $\mathcal{L}^{\text{pot}} = 0$
2. solve constraints on (q, \tilde{q})
3. IR limit $e \rightarrow \infty$, and integrate out A_m

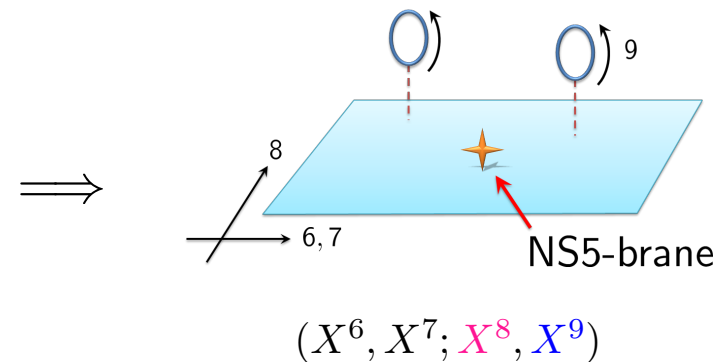

1. SUSY vacua

$$\sigma = 0 = \phi, \quad |q|^2 - |\tilde{q}|^2 = X^7 - t^7, \quad -q\tilde{q} = (X^6 - s^6) + i(X^8 - s^8)$$

2. solve constraints on (q, \tilde{q})

$$q = i e^{+i\alpha} \sqrt{|\vec{X}| + (X^7 - t^7)}, \quad \tilde{q} = i e^{-i\alpha} \frac{(X^6 - s^6) + i(X^8 - s^8)}{\sqrt{|\vec{X}| + (X^7 - t^7)}}$$

$$|D_m q|^2 + |D_m \tilde{q}|^2 = \frac{1}{2|\vec{X}|} \left[(\partial_m X^6)^2 + (\partial_m X^7)^2 + (\partial_m X^8)^2 \right] + |\vec{X}| \left(\partial_m \alpha - A_m + \Omega_i \partial_m X^i \right)^2$$

$$|\vec{X}| = \sqrt{(X^6 - s^6)^2 + (X^7 - t^7)^2 + (X^8 - s^8)^2}$$

$$\Omega_i \partial_m X^i = \frac{-(X^6 - s^6) \partial_m X^8 + (X^8 - s^8) \partial_m X^6}{|\vec{X}| (|\vec{X}| + (X^7 - t^7))}$$

3. IR limit $e \rightarrow \infty$, and integrate out A_m

$$A_m = \Omega_i \partial_m X^i + \frac{1}{|\vec{X}|} \varepsilon_{mn} \partial^n X^9$$

$$\implies \mathcal{L}_{\text{NS5}}^{\text{NLMS}} = -\frac{1}{2} \left(\frac{1}{g^2} + \frac{1}{|\vec{X}|} \right) \left[(\partial_m \vec{X})^2 + (\partial_m X^9)^2 \right] + \varepsilon^{mn} \Omega_i \partial_m X^i \partial_n X^9$$

LESSON 2 : GLSM for KK5-brane

D. Tong [hep-th/0204186](#)

J.A. Harvey and S. Jensen [hep-th/0507204](#)

K. Okuyama [hep-th/0508097](#)

$\Theta \rightarrow \Gamma$:

$$\begin{aligned} \mathcal{L}_{\text{NS5}} \ni \mathcal{L}_{\Theta} &= \int d^4\theta \left(-\frac{1}{g^2} \bar{\Theta} \Theta \right) + \left\{ \int d^2\tilde{\theta} (-\Theta) \Sigma + (\text{h.c.}) \right\} \\ &= \int d^4\theta \left\{ -\frac{1}{2g^2} (\Theta + \bar{\Theta})^2 - (\Theta + \bar{\Theta}) V \right\} + \varepsilon^{mn} \partial_m (X^9 A_n) \end{aligned}$$

↓

$$\mathcal{L}_{B\Gamma} = \int d^4\theta \left\{ -\frac{1}{2g^2} B^2 - BV - B(\Gamma + \bar{\Gamma}) \right\} + \varepsilon^{mn} \partial_m (X^9 A_n)$$

real $\bar{B} = B$; chiral $\bar{D}_{\pm} \Gamma = 0$

$\Theta \rightarrow \Gamma$:

$$\mathcal{L}_{B\Gamma} = \int d^4\theta \left\{ -\frac{1}{2g^2} B^2 - BV - (\Gamma + \bar{\Gamma})B \right\} + \varepsilon^{mn} \partial_m (X^9 A_n)$$

Integrating out $\Gamma, \bar{\Gamma}$: \rightarrow GLSM for NS5-brane

$$B = \Theta + \bar{\Theta}$$

or, Integrating out B : \rightarrow GLSM for KK5-brane

$$\frac{1}{g^2} B = -(\Gamma + \bar{\Gamma}) - V$$

duality relation :

$$\Theta = X^7 + iX^9 + \dots, \quad \Gamma = \tilde{X}^7 + i\tilde{X}^9 + \dots$$

$$\Theta + \bar{\Theta} = -g^2(\Gamma + \bar{\Gamma}) - g^2V \rightarrow$$

$$\begin{aligned} X^7 &= -g^2 \tilde{X}^7 \\ \pm(\partial_0 \pm \partial_1) X^9 &= -g^2 (D_0 \pm D_1) \tilde{X}^9 \\ D_m \tilde{X}^9 &= \partial_m \tilde{X}^9 - A_m \end{aligned}$$

$$\begin{aligned}
 \mathcal{L}_{\text{KK5}} = & \int d^4\theta \left\{ \frac{1}{e^2} \left(-\bar{\Sigma}\Sigma + \bar{\Phi}\Phi \right) + \bar{Q}e^{+2V}Q + \bar{\tilde{Q}}e^{-2V}\tilde{Q} \right\} + \int d^4\theta \left\{ \frac{g^2}{2} \left(\Gamma + \bar{\Gamma} + V \right)^2 + \frac{1}{g^2} \bar{\Psi}\Psi \right\} \\
 & + \int d^2\theta \left(-\tilde{Q}\Phi Q + (s - \Psi)\Phi \right) + (\text{h.c.}) \\
 & + \left\{ \int d^2\tilde{\theta} t \Sigma + (\text{h.c.}) \right\} + \varepsilon^{mn} \partial_m (X^9 A_n)
 \end{aligned}$$

Steps to NLSM for KK5-brane

1. SUSY vacua $\mathcal{L}^{\text{pot}} = 0$
2. solve constraints on (q, \tilde{q})
3. IR limit $e \rightarrow \infty$, and integrate out A_m

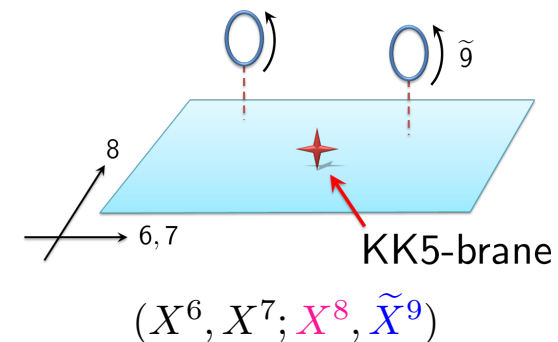

1. SUSY vacua

$$\sigma = 0 = \phi, \quad |q|^2 - |\tilde{q}|^2 = X^7 - t^7, \quad -q\tilde{q} = (X^6 - s^6) + i(X^8 - s^8)$$

2. solve constraints on (q, \tilde{q})

$$q = i e^{+i\alpha} \sqrt{|\vec{X}| + (X^7 - t^7)}, \quad \tilde{q} = i e^{-i\alpha} \frac{(X^6 - s^6) + i(X^8 - s^8)}{\sqrt{|\vec{X}| + (X^7 - t^7)}}$$

$$|D_m q|^2 + |D_m \tilde{q}|^2 = \frac{1}{2|\vec{X}|} \left[(\partial_m X^6)^2 + (\partial_m X^7)^2 + (\partial_m X^8)^2 \right] + |\vec{X}| \left(\partial_m \alpha - A_m + \Omega_i \partial_m X^i \right)^2$$

3. IR limit $e \rightarrow \infty$, and integrate out A_m

$$A_m = \frac{1}{|\vec{X}|H} (\partial_m \tilde{X}^9 - \Omega_i \partial_m X^i) + \Omega_i \partial_m X^i, \quad H = \frac{1}{g^2} + \frac{1}{|\vec{X}|}$$

$$\mathcal{L}_{\text{KK5}}^{\text{NLMSM}} = -\frac{H}{2} (\partial_m \vec{X})^2 - \frac{1}{2H} (\partial_m \tilde{X}^9 - \Omega_i \partial_m X^i)^2 + \varepsilon^{mn} \partial_m ((X^9 - t^9) A_n)$$

LESSON 3 : GLSM for 5_2^2 -brane

S. Sasaki and TK arXiv:1304.4061

M. Yata and TK arXiv:1406.0087

$\Psi \rightarrow \Xi$:

$$\begin{aligned}
 \mathcal{L}_{\text{KK5}} \ni \mathcal{L}_{\Psi} &= \int d^4\theta \frac{1}{g^2} \bar{\Psi} \Psi + \left\{ \int d^2\theta (-\Psi) \Phi + (\text{h.c.}) \right\} \\
 &= \int d^4\theta \left\{ \frac{a}{g^2} (\Psi + \bar{\Psi})^2 - (\Psi + \bar{\Psi})(C + \bar{C}) \right\} \\
 &\quad + \int d^4\theta \left\{ \frac{2a-1}{2g^2} (\Psi - \bar{\Psi})^2 - (\Psi - \bar{\Psi})(C - \bar{C}) \right\}
 \end{aligned}$$

↓

$$\begin{aligned}
 \mathcal{L}_{RSX\Xi} &= \int d^4\theta \left\{ \frac{a}{g^2} R^2 - R(C + \bar{C}) + R(\Xi_1 + \bar{\Xi}_1) + R(X + \bar{X}) \right\} \\
 &\quad + \int d^4\theta \left\{ \frac{2a-1}{2g^2} (iS)^2 - (iS)(C - \bar{C}) + iS(\Xi_2 - \bar{\Xi}_2) + iS(X - \bar{X}) \right\}
 \end{aligned}$$

$$\bar{R} = R, \quad \bar{S} = S, \quad \bar{D}_+ \Xi_{1,2} = 0 = D_- \Xi_{1,2}, \quad \bar{D}_{\pm} X = 0, \quad \Phi_a = \bar{D}_+ \bar{D}_- C_a$$

$\Psi \rightarrow \Xi$:

$$\begin{aligned} \widetilde{\mathcal{L}} = & \int d^4\theta \left\{ \frac{a}{g^2} R^2 - R(C + \bar{C}) + R(\Xi_1 + \bar{\Xi}_1) + R(X + \bar{X}) \right\} \\ & + \int d^4\theta \left\{ \frac{2a-1}{2g^2} (iS)^2 - (iS)(C - \bar{C}) + iS(\Xi_2 - \bar{\Xi}_2) + iS(X - \bar{X}) \right\} \end{aligned}$$

Integrating out Ξ_1, Ξ_2, X : \rightarrow GLSM for KK5-brane

or, Integrating out R, Ξ_2 : \rightarrow GLSM for 5_2^2 -brane

$$\frac{2a}{g^2} R = -(\Xi_1 + \bar{\Xi}_1) + (C + \bar{C})$$

duality relation at $a = \frac{1}{2}$:

$$\Psi = X^6 + iX^8 + \dots$$

$$\Psi + \bar{\Psi} = -g^2(\Xi_1 + \bar{\Xi}_1) + g^2(C + \bar{C})$$

$$\begin{aligned} X^6 & \sim \text{real part of } \Xi \\ \partial X^8 & \sim \partial(\text{imaginary part of } \Xi) + \text{“gauge” fields in } C_a \end{aligned}$$

$$\begin{aligned} \mathcal{L}^{\text{kin}} &= \frac{1}{e^2} \left[\frac{1}{2} (F_{01})^2 - |\partial_m \sigma|^2 - |\partial_m \phi|^2 \right] - \left[|D_m q|^2 + |D_m \tilde{q}|^2 \right] \\ &\quad - \frac{1}{2g^2} \left[(\partial_m X^6)^2 + (\partial_m X^7)^2 \right] - \frac{g^2}{2} \left[(\partial_m \tilde{X}^8)^2 + (D_m \tilde{X}^9)^2 \right] + (X^9 - t^9) F_{01} \end{aligned}$$

$$\begin{aligned} \mathcal{L}^{\text{pot}} &= -2(|\sigma|^2 + 4|M_c|^2)(|q|^2 + |\tilde{q}|^2 + g^2) \\ &\quad - \frac{e^2}{2} \left(|q|^2 - |\tilde{q}|^2 - (X^7 - t^7) \right)^2 - e^2 \left| q\tilde{q} + (X^6 - s^6) + i(X^8 - s^8) \right|^2 \\ &\quad + \frac{g^2}{2} (A_{c=} + \bar{A}_{c=})(B_{c\neq} + \bar{B}_{c\neq}) \end{aligned}$$

$$(\partial_0 + \partial_1)X^8 = -g^2(\partial_0 + \partial_1)\tilde{X}^8 - g^2(B_{c\neq} + \bar{B}_{c\neq})$$

$$(\partial_0 - \partial_1)X^8 = +g^2(\partial_0 - \partial_1)\tilde{X}^8 - g^2(A_{c=} + \bar{A}_{c=})$$

$$+\frac{g^2}{2}(A_{c=} + \bar{A}_{c=})(B_{c\neq} + \bar{B}_{c\neq}) = -\frac{1}{2g^2}(\partial_m X^8)^2 + \frac{g^2}{2}(\partial_m \tilde{X}^8)^2 + \varepsilon^{mn}(\partial_m X^8)(\partial_n \tilde{X}^8)$$

Steps to NLSM for 5_2^2 -brane

1. search SUSY vacua $\mathcal{L}^{\text{pot}} = 0$
2. solve constraints of charged HM (Q, \tilde{Q})
3. integrate out VM (V, Φ) in IR
- ★4. integrate s^8 , and solve EOM for X^8 in $\Psi - \bar{\Psi}$

Why is $\Psi - \bar{\Psi}$ integrated out at the final step?

→ X^8 in $\Psi - \bar{\Psi}$ still appears as a winding coordinate in string worldsheet sigma model.

We should **not** integrate it out **before** integrating-out of VM.

Step 1.,2.,3. :

$$\begin{aligned}
 \mathcal{L} = & -\frac{1}{2}H \left[(\partial_m X^6)^2 + (\partial_m X^7)^2 + (\partial_m X^8)^2 \right] - \frac{1}{2H} (\partial_m \tilde{X}^9)^2 \\
 & - \frac{(\Omega_8)^2}{2H} (\partial_m X^8)^2 + \frac{\Omega_8}{H} (\partial_m X^8) (\partial^m \tilde{X}^9) \\
 & - \frac{(\Omega_6)^2}{2H} (\partial_m X^6)^2 - \frac{\Omega_6 \Omega_8}{H} (\partial_m X^6) (\partial^m X^8) + \frac{\Omega_6}{H} (\partial_m X^6) (\partial^m \tilde{X}^9) \\
 & + \varepsilon^{mn} \partial_m ((X^9 - t^9) A_n) + \varepsilon^{mn} (\partial_m X^8) (\partial_n \tilde{X}^8)
 \end{aligned}$$

$$H = \frac{1}{g^2} + \frac{1}{|\vec{X}|}, \quad \Omega_6 = \frac{X^8 - s^8}{|\vec{X}|(|\vec{X}| + (X^7 - t^7))}, \quad \Omega_8 = -\frac{X^6 - s^6}{|\vec{X}|(|\vec{X}| + (X^7 - t^7))}$$

$$A_m = \frac{1}{|\vec{X}|H} (\partial_m \tilde{X}^9 - \Omega_i \partial_m X^i) + \Omega_i \partial_m X^i$$

Step 4. : $s^8 = (2\pi R_8) s \xrightarrow{\text{integral over } s}$ emerge isometry

$$\left\{ \begin{array}{ll} H \rightarrow 1/g^2 + \log(\Lambda/\varrho) & : \text{co-dim. 2} \quad \varrho = \sqrt{(X^6 - s^6)^2 + (X^7 - t^7)^2} \\ \Omega_6 \rightarrow 0 & : \text{isometry along } X^8 \\ \Omega_8 \rightarrow \arctan\left(\frac{X^7 - t^7}{X^6 - s^6}\right) \equiv \vartheta & : \text{"non-single-valued" metric} \end{array} \right.$$

EOM for X^8 : $\partial_m X^8 = \frac{H}{K} \left[\frac{\vartheta}{H} (\partial_m \tilde{X}^9) + \varepsilon_{mn} (\partial^n \tilde{X}^8) \right]$

$K = H^2 + \vartheta^2$

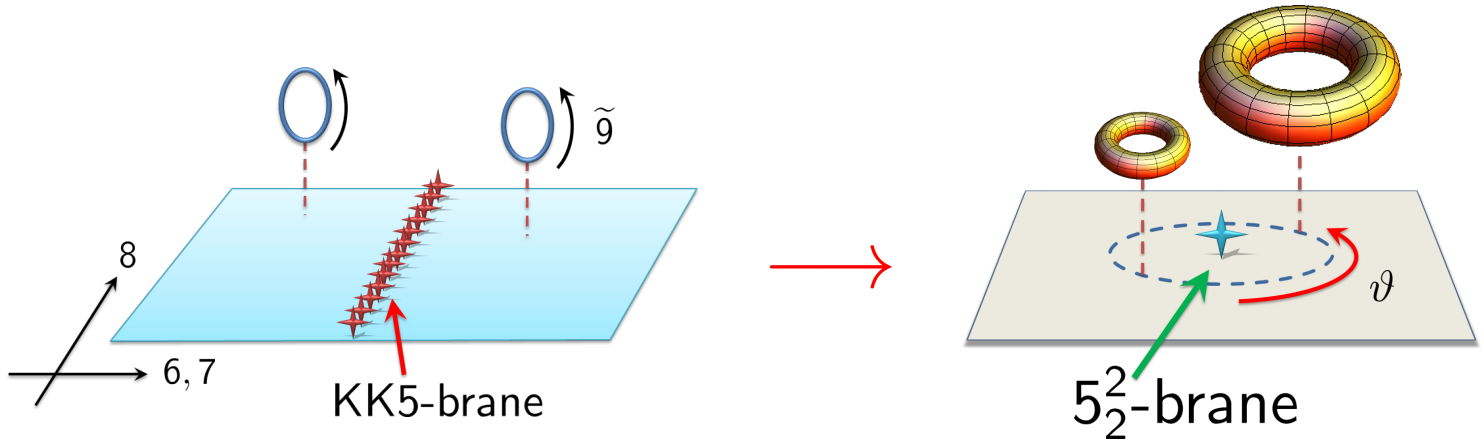

$$\mathcal{L}_{\text{exotic}}^{\text{NLSM}} = -\frac{H}{2} \left[(\partial_m \varrho)^2 + \varrho^2 (\partial_m \vartheta)^2 \right] - \frac{H}{2K} \left[(\partial_m \tilde{X}^8)^2 + (\partial_m \tilde{X}^9)^2 \right] \\ - \frac{\vartheta}{K} \varepsilon^{mn} (\partial_m \tilde{X}^8) (\partial_n \tilde{X}^9) + \varepsilon^{mn} \partial_m ((X^9 - t^9) A_n)$$

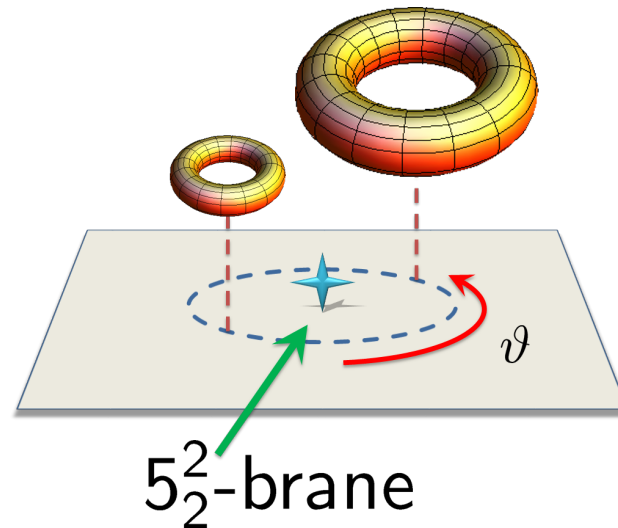

We obtained NLSM for **Exotic** 5_2^2 -brane.

Exotic feature comes from the **string winding modes**.

$$\mathcal{L}_{\text{exotic}}^{\text{NLSM}} = -\frac{H}{2} \left[(\partial_m \varrho)^2 + \varrho^2 (\partial_m \vartheta)^2 \right] - \frac{H}{2K} \left[(\partial_m \tilde{X}^8)^2 + (\partial_m \tilde{X}^9)^2 \right] \\ - \frac{\vartheta}{K} \varepsilon^{mn} (\partial_m \tilde{X}^8) (\partial_n \tilde{X}^9) + \varepsilon^{mn} \partial_m ((X^9 - t^9) A_n)$$

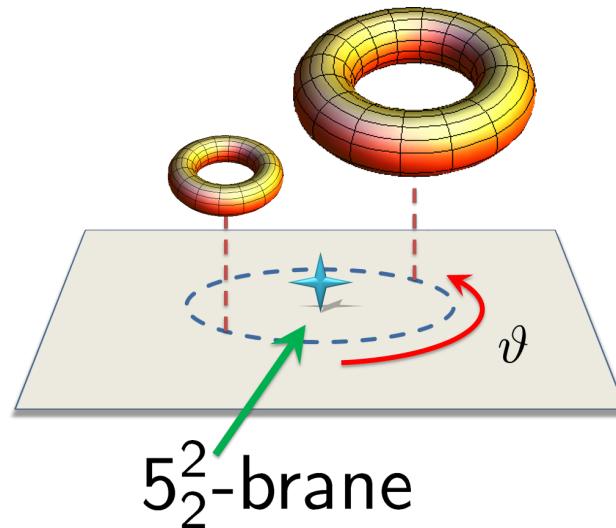

Spacetime picture involving string winding modes

beyond the Einstein's view of gravity !

Quantum corrections to five-branes

String Worldsheet Instanton Corrections



Deform target space geometry by momentum and/or winding effects

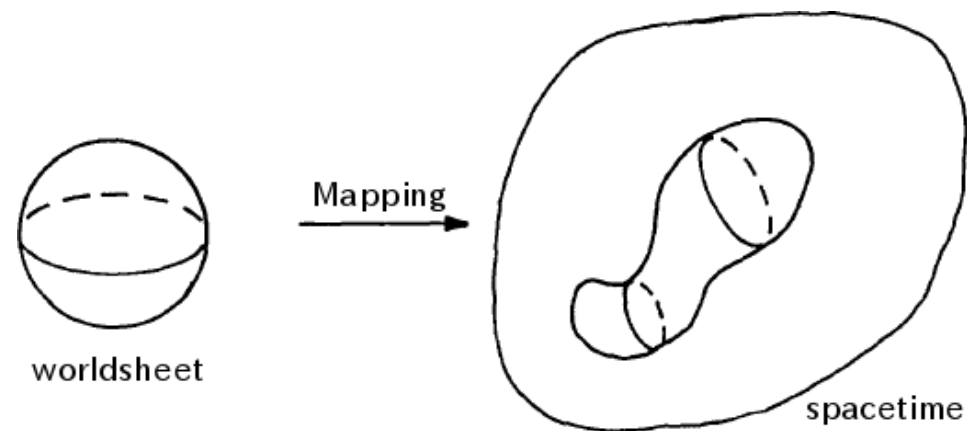

Figure from E. Witten CMP 92 (1984) 455

Again, GLSM is a powerful tool :

Worldsheet instantons in NLSM can be captured by
vortex solution in gauge theory

▶ NS5-brane

$$H = \frac{1}{g^2} + \frac{1}{|\vec{X}|} : \text{radius of } X^9$$

$g \rightarrow 0$ case	general $ \vec{X} $	$g \rightarrow \infty$ case	$ \vec{X} \rightarrow 0$	$ \vec{X} \rightarrow \infty$
radius of X^9	∞	radius of X^9	∞	0
KK-modes	light	KK-modes	light	heavy
winding modes	heavy	winding modes	heavy	light

▶ NS5-brane

$$H = \frac{1}{g^2} + \frac{1}{|\vec{X}|} : \text{radius of } X^9$$

$g \rightarrow 0$ case	general $ \vec{X} $	$g \rightarrow \infty$ case	$ \vec{X} \rightarrow 0$	$ \vec{X} \rightarrow \infty$
radius of X^9	∞	radius of X^9	∞	0
KK-modes	light	KK-modes	light	heavy
winding modes	heavy	winding modes	heavy	light

GLSM for NS5-brane has $X^9 F_{01}$



KK-mode corrections can be captured by vortex solution in gauge theory

Worldsheet instanton corrections to NS5-brane :

$$X^9 F_{01} \text{ in GLSM}$$

→ **un**folding effect on compactified circle X^9

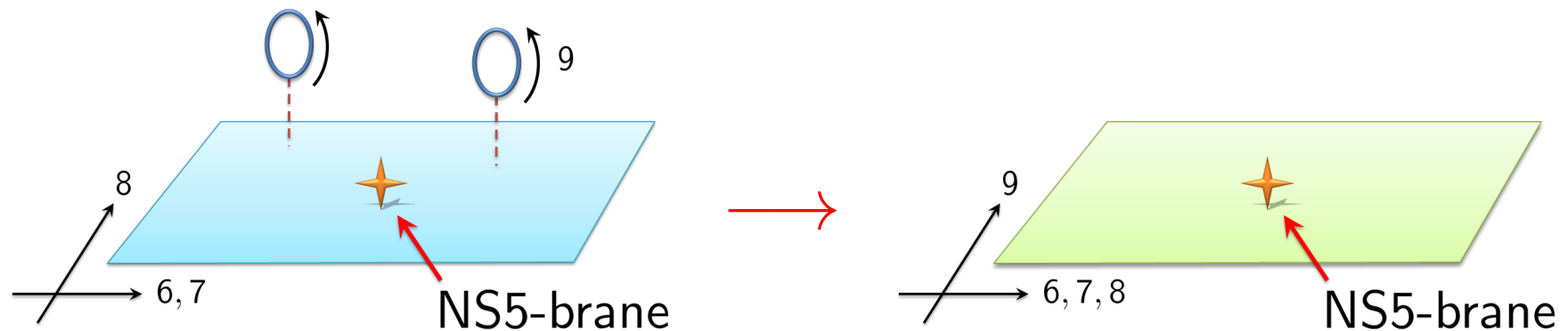

Worldsheet instanton corrections to NS5-brane :

$$X^9 F_{01} \text{ in GLSM}$$

→ **un**folding effect on compactified circle X^9

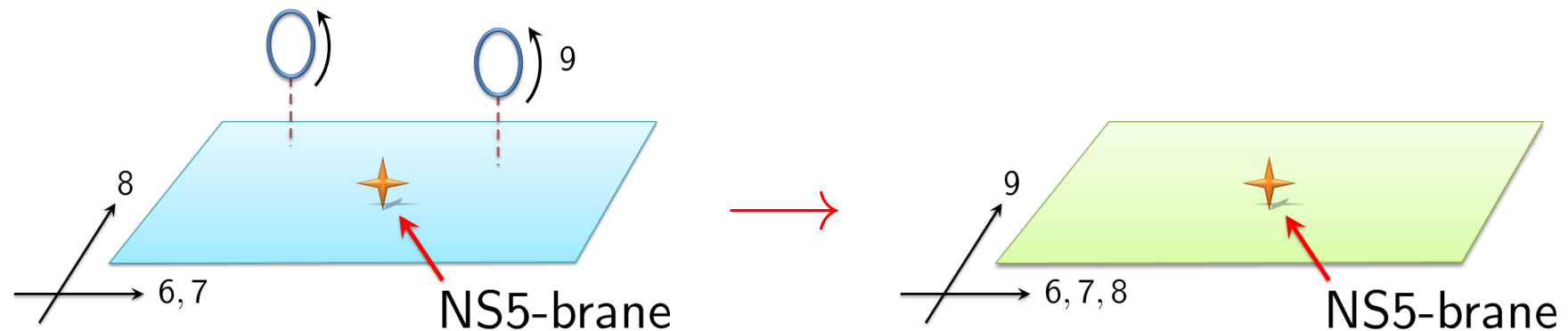

$$\begin{aligned}
 H &= \frac{1}{g^2} + \frac{1}{|\vec{X}|} \rightarrow \frac{1}{g^2} + \frac{1}{|\vec{X}|} \sum_{n=1}^{\infty} e^{-n|\vec{X}|} \left[e^{+inX^9} + e^{-inX^9} \right] \\
 &= \frac{1}{g^2} + \frac{1}{|\vec{X}|} \frac{\sinh(|\vec{X}|)}{\cosh(|\vec{X}|) - \cos(X^9)}
 \end{aligned}$$

D. Tong hep-th/0204186

▶ KK5-brane

$$H^{-1} = \left(\frac{1}{g^2} + \frac{1}{|\vec{X}|} \right)^{-1} : \text{radius of } \tilde{X}^9$$

$g \rightarrow 0$ case	general $ \vec{X} $	$g \rightarrow \infty$ case	$ \vec{X} \rightarrow 0$	$ \vec{X} \rightarrow \infty$
radius of \tilde{X}^9	0	radius of \tilde{X}^9	0	∞
KK-modes	heavy	KK-modes	heavy	light
winding modes	light	winding modes	light	heavy

▶ KK5-brane

$$H^{-1} = \left(\frac{1}{g^2} + \frac{1}{|\vec{X}|} \right)^{-1} : \text{radius of } \tilde{X}^9$$

$g \rightarrow 0$ case	general $ \vec{X} $	$g \rightarrow \infty$ case	$ \vec{X} \rightarrow 0$	$ \vec{X} \rightarrow \infty$
radius of \tilde{X}^9	0	radius of \tilde{X}^9	0	∞
KK-modes	heavy	KK-modes	heavy	light
winding modes	light	winding modes	light	heavy

GLSM for KK5-brane has $\varepsilon^{mn} \partial_m (X^9 A_n)$



Winding mode corrections can be captured by vortex solution in gauge theory

Worldsheet instanton corrections to KK5-brane :

$$\varepsilon^{mn} \partial_m (X^9 A_n) \text{ in GLSM}$$

→ string **winding modes** along X^9

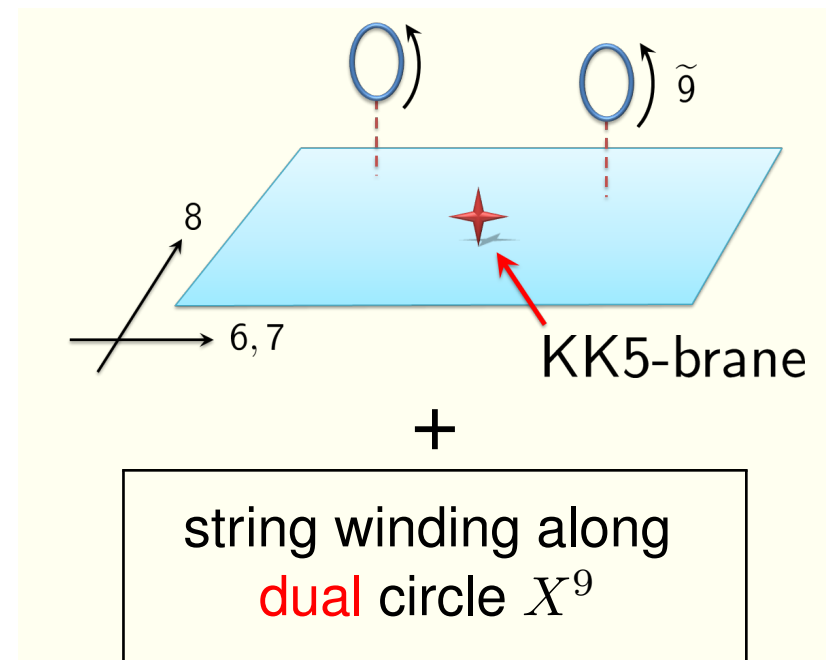
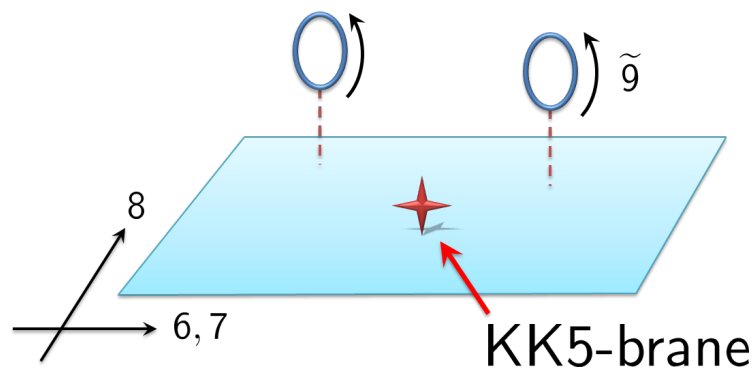

$$H \rightarrow \frac{1}{g^2} + \frac{1}{|\vec{X}|} \frac{\sinh(|\vec{X}|)}{\cosh(|\vec{X}|) - \cos(X^9)}$$

D. Tong hep-th/0204186; J. Harvey and S. Jensen hep-th/0507204; K. Okuyama hep-th/0508097

► 5_2^2 -brane

$$\frac{H}{K} : \text{radius of } \tilde{X}^9 \quad H = \frac{1}{g^2} + \log \frac{\Lambda}{\varrho}, K = H^2 + \vartheta^2$$

$g \rightarrow 0$ case	general ϱ	$g \rightarrow \infty$ case	$\varrho \rightarrow 0$	$\varrho \rightarrow \Lambda$	
radius of \tilde{X}^9	0	radius of \tilde{X}^9	0	0	∞ at $\vartheta = 0$
KK-modes	heavy	KK-modes	heavy	heavy	light at $\vartheta = 0$
winding modes	light	winding modes	light	light	heavy at $\vartheta = 0$

▶ 5_2^2 -brane

$$\frac{H}{K} : \text{radius of } \tilde{X}^9 \quad H = \frac{1}{g^2} + \log \frac{\Lambda}{\varrho}, K = H^2 + \vartheta^2$$

$g \rightarrow 0$ case	general ϱ	$g \rightarrow \infty$ case	$\varrho \rightarrow 0$	$\varrho \rightarrow \Lambda$	
radius of \tilde{X}^9	0	radius of \tilde{X}^9	0	0	∞ at $\vartheta = 0$
KK-modes	heavy	KK-modes	heavy	heavy	light at $\vartheta = 0$
winding modes	light	winding modes	light	light	heavy at $\vartheta = 0$

GLSM for 5_2^2 with **one** gauged isometry has $\varepsilon^{mn} \partial_m (X^9 A_n)$



Winding mode corrections can be captured by vortex solution in gauge theory

Worldsheet instanton corrections to 5_2^2 -brane with **one** gauged isometry :

$$\varepsilon^{mn} \partial_m (X^9 A_n) \text{ in GLSM}$$

→ string **winding modes** along X^9

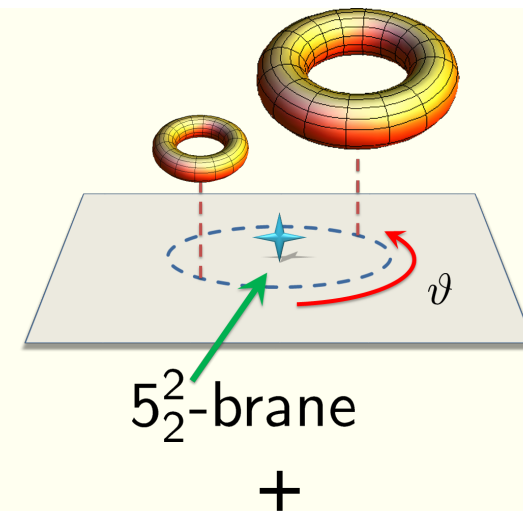
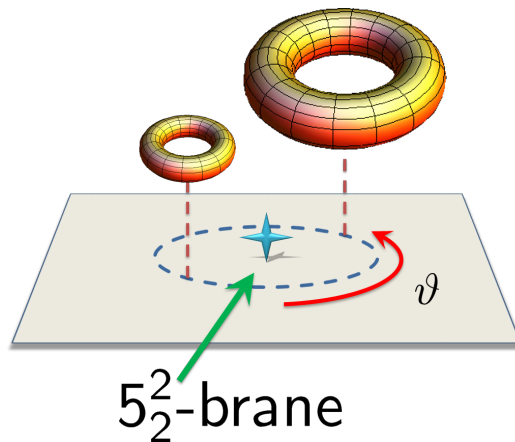

string winding along
dual circle X^9

$$H \rightarrow \frac{1}{g^2} + \log \frac{\Lambda}{\varrho} + \sum_{n \neq 0} \exp(i n X^9) K_0(|n| \varrho)$$

Result

Quantum corrections can be traced by Vortices in GLSM:

$$\mathcal{L}_{\text{topological}}^{\text{GLSM}} = X^9 F_{01} + \dots$$

$$H = 1 + \log\left(\frac{\Lambda}{\varrho}\right) \rightarrow 1 + \log\left(\frac{\Lambda}{\varrho}\right) + \sum_{n \neq 0} \exp(inX^9) K_0(|n|\varrho)$$

$K_0(x)$: modified Bessel function of the second kind

X^9 is ...
 physical coordinate in NS5
 dual coordinate in KK5
 dual coordinate in 5_2^2

Worldvolume action of exotic 5_2^2 -brane

Worldvolume action of 5_2^2 -brane could be obtained from

D5-brane's action via S- and T-dualities
KK6-brane action via reduction and T-duality
M5-brane action via reduction and T-dualities

Different point: **Two** isometries along transverse directions

How to describe its worldvolume theory with isometries?

Worldvolume action of 5_2^2 -brane could be obtained from

D5-brane's action via S- and T-dualities
KK6-brane action via reduction and T-duality
M5-brane action via reduction and T-dualities

Different point: **Two** isometries along transverse directions

How to describe its worldvolume theory with isometries?

Already Known!

[Bergshoeff et al hep-th/9706117](#)

Worldvolume action with WZ-term is **gauged** with respect to isometries

ex.) gravity sector of KK6-brane action with gauged isometry in M-theory

$$\begin{aligned}
 \mathcal{L}_{\text{KK6}}^{\text{M}} &= -\frac{1}{2} T_{\text{KK6}}^{\text{M}} \sqrt{-\gamma} \left(k^{\frac{4}{7}} \gamma^{ab} D_a X^\mu D_b X^\nu g_{\mu\nu} - 5 \right) \\
 &= -T_{\text{KK6}}^{\text{M}} k^2 \sqrt{-\det(D_a X^\mu D_b X^\nu g_{\mu\nu})} \\
 &= -T_{\text{KK6}}^{\text{M}} k^2 \sqrt{-\det(\partial_a X^\mu \partial_b X^\nu \Pi_{\mu\nu})}
 \end{aligned}$$

$$D_a X^\mu = \partial_a X^\mu + C_a k^\mu \quad k^\mu : \text{Killing vector}$$

$$\Pi_{\mu\nu} = g_{\mu\nu} - \frac{k^\mu k^\nu}{k^2}$$

- ✓ Construct the worldvolume action with WZ-term in a covariant way:

$$\text{KK6} \xrightarrow{\text{reduction}} \text{KK5 in IIA} \xrightarrow{\text{T-duality}} 5_2^2 \text{ in IIB}$$

$$\text{M5} \xrightarrow{\text{reduction}} \text{NS5 in IIA} \xrightarrow{\text{T-dualities}} 5_2^2 \text{ in IIA}$$

- ✓ 5_2^2 -branes in heterotic theories can be obtained by truncation:

$$5_2^2 \text{ in IIB} \xrightarrow[\mathcal{N}=(1,1) \rightarrow \mathcal{N}=(1,0)]{\text{RR} = 0} 5_2^2 \text{ in HSO}$$

$$5_2^2 \text{ in IIA} \xrightarrow[\mathcal{N}=(2,0) \rightarrow \mathcal{N}=(1,0)]{\text{RR} = 0} 5_2^2 \text{ in HE8}$$

$$\begin{aligned}
 S_{5_2^2}^{\text{IB}} &= -T_{5_2^2} \int d^6\xi e^{-2\phi} (\det h_{IJ}) \sqrt{1 + e^{+2\phi} (\det h_{IJ})^{-1} (i_{k_1} i_{k_2} (C^{(2)} + C^{(0)} B))^2} \\
 &\quad \times \sqrt{-\det \left[\Pi_{\mu\nu}(k_2) \partial_a X^\mu \partial_b X^\nu + \frac{K_a^{(1)} K_b^{(1)}}{(k_2)^2} - \frac{(k_2)^2 (K_a^{(2)} K_b^{(2)} - K_a^{(3)} K_b^{(3)})}{(\det h_{IJ})} + \lambda \mathcal{F}_{ab} \right]} \\
 &\quad - \mu_5 \int_{\mathcal{M}_6} \left[P[i_{k_1} i_{k_2} B^{(8,2)}] - \frac{1}{2} P[\tilde{B} \wedge \tilde{C}^{(2)} \wedge \tilde{C}^{(2)}] + \lambda P[\tilde{C}^{(4)} + \tilde{C}^{(2)} \wedge \tilde{B}] \wedge \tilde{F} \right. \\
 &\quad \left. - \frac{\lambda^2}{2!} P[\tilde{B}] \wedge \tilde{F} \wedge \tilde{F} + \frac{\lambda^3}{3!} \frac{i_{k_1} i_{k_2} (C^{(2)} + C^{(0)} B)}{(i_{k_1} i_{k_2} (C^{(2)} + C^{(0)} B))^2 + e^{-2\phi} (\det h_{IJ})} \tilde{F} \wedge \tilde{F} \wedge \tilde{F} \right]
 \end{aligned}$$

$$h_{IJ} = k_I^\mu k_J^\nu (g_{\mu\nu} + B_{\mu\nu}), \quad \text{etc..}$$